



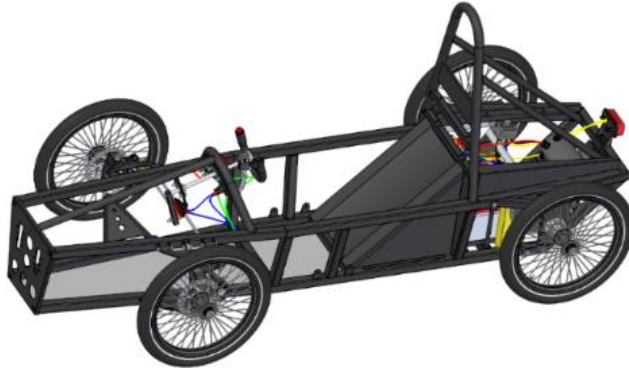
Supported by
SIEMENS

Formula 24

Curriculum/Build Guide

Emphasis on 7th -10th grade standards

Welcome to GreenpowerUSA



This guide is a companion to the GreenpowerUSA Formula 24 (F24) race car kit. The purpose of this document is to frame the building and racing of the F24 with curriculum suitable for 7th – 10th grade students. This curriculum encompasses Science, Math, College and Career Readiness, English/Language Arts, Speaking and Writing Common Core standards and Technology standards for these grades. Sixth grade standards are included as a scaffolding reference. The science focus includes, but is not limited to, basic electrical concepts, forces, Newton's laws of motion and friction. Math standards explored include geometry as well as algebraic concepts. The College and Career Readiness Unit (Unit 2) encompasses Reading, Speaking, English/Language Arts, and Writing standards but they also can be addressed with the suggested activities in many of the other units. An approximate pacing is provided as a guideline, though the process can be compressed or extended based on individual needs. Allowing adequate time for suggested activities will enhance the overall learning.

The build process is rich in hands-on experiences and this guide includes supporting activities that broaden the scope of these concepts. The units that contain components that can be modified to improve performance have activities defined as post-build. These concepts can be revisited after the car is complete and data collection has begun. They are housed in the corresponding build unit for ease of reference to the components affected by a desired change. The last unit focuses on data to be collected while driving. Data analysis provides a variety of opportunities for math exploration as well as discoveries of the modification vs performance relationship. Throughout all sections, safety is always first and foremost.

The engineering design aspects of this project can be explored to many levels. Students can understand the engineering design life cycle of projects created in the real world from requirements to prototype and test. Students can learn about design and modeling through the use of CAD software such as Siemens' Solid Edge. Scaled or full parts can be modeled and even 3D printed, if the capability is available.

Writing is essential to success in college and the workplace. And technical writing is a very important part of the engineering process. Engineers should be able to describe components and/or actions, give direction, report results, defend decisions and inform readers about their project. In this context, reflective writing is important to the learning process, prompting

internalization of concepts and sparking improvements. An engineering notebook is a great way to foster this best practice habit. Pairing with an English teacher provides a cross-curricular component and sharpens the grammatical and structural skills of writing. This emphasizes that no matter what the subject, writing construction is always important.

Greenpower is a dynamic STEM (Science, Technology, Engineering, and Mathematics) initiative that encompasses a wide variety of skills. The goal of this program is to expose students to the world of engineering and innovation. That goal is accomplished in an exciting and engaging way with Greenpower.

Table of Contents

Welcome to GreenpowerUSA	2
Unit 1: Introduction and Safety	7
1.1 General Overview	7
1.2 Reference Standards	8
1.3 Materials and Tools	8
1.4 Unit Concepts and Procedures	8
1.4.1 Introduction to Greenpower	8
1.4.2 General Safety Guidelines	9
1.4.3 Safety Test and Contract	9
1.4.4 Release Forms	10
1.5 Supporting Activities	10
1.6 Supplemental Resources for Safety Unit	11
1.7 Teacher Recommendations	16
Unit 2: College and Career Readiness	17
2.1 Reference Standards	17
2.2 Introduction to Professional Communication	18
2.2.1 Supporting Activities	19
2.3 Team Structure	20
2.3.1 Manager/Team Lead	21

2.3.2 Safety Manager	21
2.3.3 Public Relations Manager	21
2.3.4 Materials Manager	21
2.3.5 Build Team Leader.....	21
2.3.6 Data Manager	22
2.3.7 Driving Team.....	22
2.3.8 Pit Chief	22
2.3.9 Supporting Activities	22
2.4 Teacher Recommendations.....	23
Unit 3: Getting Started: Tools and Body Basics	24
3.1 Reference Standards	24
3.2 General Overview.....	25
3.3 Materials and Tools.....	26
3.4 Unit Procedures	26
3.4.1 Tool Basics.....	26
3.4.2 Installing the Floorboard.....	27
3.5 Supporting Activities.....	28
3.6 Teacher Recommendations.....	30
Unit 4: Steering and Brake Assembly	31
4.1 Reference Standards	31
4.3 Materials and Tools.....	33
4.4 Unit Procedures	33
4.4.1 Installing Wishbone Assembly.....	33
4.4.2 Steering Column Assembly	38
4.4.3 Installing Steering Linkage Assembly	41
4.4.4 Tire Assembly	43
4.4.5 Installing Brake Assembly.....	46
4.4.6 Tuning Your Car (Post Build).....	49
4.5 Supporting Activities.....	49
4.6 Teacher Recommendations.....	51
Unit 5: Drive Assembly	52

5.1 Reference Standards	52
5.2 General Overview	53
5.3 Materials and Tools	54
5.4 Unit Procedure	54
5.4.1 Installing the Rear Drive Wheel Assembly	54
5.4.2 Installing the Drive Motor and Chain Assembly	61
5.5 Supporting Activities	68
5.6 Teacher Recommendations	70
Unit 6: Electrical Components	71
6.1 Reference Standards	71
6.2 General Overview	71
6.3 Materials and Tools	72
6.4 Unit Procedures	73
6.5 Supporting Activities	82
6.6 Teacher Recommendation	83
Unit 7: Safety Components	84
7.1 Reference Standards	84
7.2 General Overview	85
7.3 Materials and Tools	85
7.4 Unit Procedures	86
7.5 Supporting Activities	88
7.6 Teacher Recommendations	90
Unit 8: Body Application	91
8.1 Reference Standards	91
8.2 General Overview	91
8.3 Materials and Tools	92
8.4 Unit Procedures	92
8.5 Supporting Activities	93
8.6 Teacher Recommendations	93
Unit 9: Driving, Data Collection and Analysis	94
9.1 Reference Standards	94

9.2 General Overview	95
9.3 Materials and Tools	95
9.4 Unit Procedures	96
9.5 Supporting Activities.....	96
9.6 Teacher Recommendations.....	98
Appendix A:	99
Standards	99



Unit 1: Introduction and Safety

1.1 General Overview

The GreenpowerUSA program focuses on the design, build and modification of an F 24 race car. This in turn provides exposure to basic curricular concepts in all areas of STEM as well as design, innovation, sustainability, budgeting, marketing, and teamwork. These concepts are woven throughout the curriculum especially in the supporting activities. As this program begins, students explore the GreenpowerUSA program as a whole to gain the “Big Picture.” However, safety is the main factor in this unit. Safety will be discussed with all involved students. This includes, but is not limited to, safety within the following areas: equipment, general classroom procedures, vehicle testing, and race/event activities. It is recommended that each student and their parent/guardian sign a consent form and the student pass a safety test before beginning the project. Safety also involves protection of personal identity where required; therefore, media consent forms should be obtained for each student.

Greenpower does not control the implementation of the program by the entities (schools/individual organizations) involved. Therefore, safety is the sole responsibility of the implementing organization. Each entity will introduce proper protocols for safe implementation of the Greenpower Program. Greenpower recommends faculty/staff be trained in appropriate safety measures as dictated by their organization, including effective supervision of students.

Objectives

The students will:

- Identify safety issues.
- Follow procedures in response to a safety event.
- Demonstrate understanding of all safety requirements with 100% proficiency.
- Complete all necessary documentation to participate in the program.
- Begin an Engineering notebook.

Key Vocabulary

- Consent
- Liability
- Risk
- Waiver

Pacing

This unit should be completed before any build work begins. You will need approximately 1.5 weeks to complete the introduction to Greenpower and safety.

1.2 Reference Standards

For the complete standard, please see Appendix A.

Language Standards

- L6-8.1, L9-10.1 (Demonstrate command of English grammar)
- L6-8.2, L9-10.2 (Demonstrate command of punctuation)
- L6-8.3, L9-10.3 (Use knowledge of language and its conventions in writing, speaking, reading, and listening)

Writing

- W6-8.1, W9-10.1, CCRASL-W1 (Write arguments to support claims)
- W6-8.4, W9-10.4, CCRASL-W4 (Produce clear and coherent writing)
- W6-8.5, W9-10.5, CCRASL-W5 (Develop and strengthen writing by editing)
- W6-8.8, W9-10.8, CCRASL-W8 (Gather and summarize relevant, credible information)
- W6-8.9, W9-10.9, CCRASL-W9 (Draw evidence to support writing)
- W6-8.10, W9-10.10, CCRASL-W10 (Write routinely for discipline-specific purposes)

Environmental

- ES9-12.1 (Non-renewable energy sources)
- ES9-12.14 (Conservation to minimize impacts on natural systems)

1.3 Materials and Tools

Materials needed for this unit include samples of tools used to construct the car, i.e. wrenches, screw drivers, mallet/hammer, etc. to demonstrate tool safety. Also needed are copies of safety contracts and consent forms. Each student will take a Safety test and be given a printed copy of the safety contract (see section 1.5).

1.4 Unit Concepts and Procedures

In this unit, students will begin with an introduction to GreenpowerUSA. They will investigate the cars, races, rules and the regulations. Since safety is a very important to the process, it will be the main focus of this unit. The instructor will review general safety guidelines. Students will be required to pass a test and complete a safety contract. General safety guidelines as well as areas more specific to tools and electricity are listed below. Discuss the importance of safety, as well as how things can go wrong, to prevent harm to the students or equipment. This discussion will encompass the following Science/Health standards. Keep in mind that the sample forms included in this unit's supplement are provided as a suggestion and should be tailored for each entity's specific requirements.

1.4.1 Introduction to Greenpower

As an introduction to this program, students should understand the premise behind Greenpower. GreenpowerUSA's objective is to advance education in the subjects of sustainable engineering and technology for young people. They maintain a website, www.greenpowerusa.net, as a resource for those interested in the cars, races and related information. Students will investigate the various levels of cars to understand the Formula 24 and where it falls in the series. Students then need to study the rules and regulations

related to the races and also the requirements and specification that the car must accommodate. These rules and regulations and their impact on designing and building the car should be taken into consideration with each step in the design and build process so that the car will pass the scrutineering required at sanctioned races.

1.4.2 General Safety Guidelines

The Greenpower car is designed to be as safe as possible. However, certain safety aspects should be taken into account. Make sure all students know how to use each tool safely and correctly. The Greenpower project encourages students to work in groups or pairs to reduce the risk of injury.

- Make sure the students and lead teacher are familiar with all aspects of the car before the build is started.
- Students should be supervised at all times.
- Wear protective gear, such as safety glasses, when using drills, hammers, etc.
- Do not wear baggy clothing or long dangling items.
- Long hair should always be tied back.
- Closed-toed shoes should be worn at all times.
- Concentrate on the task no matter how trivial it seems.

General Tool Safety

- Use a hand tool for the job it was manufactured to perform.
- Inspect tools for cracks, chips, loose handles and wear.
- Strike the hammer with the face parallel to the surface being struck. Off-center blows can throw dangerous splinters into the air or catch fingers.
- Do not use a hammer to strike another hammer.
- A screwdriver blade tip should fit the slot in the screw. It should not fit outside the groove.
- Do not strike a screwdriver handle with a hammer - it can break/slide off.
- Concentrate! If the screwdriver blade slips, you can get hurt.
- Never use the handle of any tool as a striking tool itself.
- Do not touch the drill bit immediately after operation; it may be extremely hot.
- Keep both hands on the drill at all times. (Drill bits can break apart and cause injury.)
- Make sure all electrical tools are turned off after use and are stored properly.

General Electrical Safety - Electricity is dangerous!

- Touching both terminals of the batteries with anything metal will result in a burn or electrical shock.
- The car should never be worked on while the batteries are connected.
- Make sure all wires are out of the way of moving parts (i.e. sprockets, chains).
- Batteries are heavy and should not be moved by young students. (Use your discretion in the selection of students who handle batteries.)

1.4.3 Safety Test and Contract

After reviewing rules concerning tools, procedures and behavior, each student should complete a safety contract (see section 1.5, for a sample) as well as pass a safety unit test.

1.4.4 Release Forms

Your school/district or other organization **MUST** provide appropriate release forms (i.e. liability waivers, consent forms, etc.). In order for students to participate in the program, all signed documents must be on file with the lead teacher. Additional documentation will be required to participate in Greenpower sanctioned events. The sample forms in Section 1.5 are not meant to be exhaustive and should always be tailored and approved by your organization.

1.5 Supporting Activities

Greenpower Explained (ES9-12.1,14)

- Students investigate the Greenpower website to understand the Formula 24 car, its races and regulations.
- Students use the web to investigate sustainable energy, green engineering and electric cars.

Play it Safe (W6-8.6)

- Students investigate potential safety concerns as well as appropriate prevention techniques and injury responses.
- Student create safety posters to position in appropriate areas of the classroom/lab.

Let's Log! (W6-10.1,4,5,8,9,10; CCRASL-W1,4,5,8,9,10; L6-10.1,2,3)

- Have students begin their engineering notebook by writing, in their own words, the importance of safety rules and why it is important to abide by them. Examples specific to Greenpower should be used.

1.6 Supplemental Resources for Safety Unit

(Print Student's Name)

Greenpower Build Safety Contract

The Greenpower Car is a fun and exciting process and deserves respect. Building anything with hand and power tools in a classroom setting can have potential hazards. Equipment that is used can be dangerous if not handled properly. To ensure a safe environment, a list of rules and instructions have been developed and is called the Greenpower Build Safety Contract. These rules must be followed at all times. Additional safety instructions will be given whenever specific to an activity. It is recommended that no student be allowed to participate in Greenpower activities until this contract has been signed by both the student and a parent or guardian.

SAFETY RULES

1. Conduct yourself in a responsible manner at all times in the Greenpower Lab. Horseplay, practical jokes, and pranks will not be tolerated. No running, skipping, hurrying or touching each other.
2. Pay full attention to the task you are doing. Concentrate. Do not interrupt or disturb others who are concentrating on their task.
3. Follow all written and verbal instructions carefully. Ask questions if you do not understand the instructions.
4. Never eat or drink in the Greenpower Lab.
5. Dress properly—long hair must be tied back, no dangling jewelry (necklaces, earrings, lanyards...), and no loose or baggy clothing. Closed-toed shoes are a must!
6. Know where the exits are located and what to do in case of an emergency or fire drill.
7. Wear safety glasses or goggles when instructed. Any time you are hitting, drilling or puncturing something, you must protect your eyes and the eyes of others in your area. There will be no exceptions to this rule!
8. Keep the work area and the Greenpower Lab neat and clean. Only necessary items should be in the area.
9. Do not remove tools, equipment, supplies, or other materials in the Greenpower Lab or the storage closet without permission from the teacher.
10. Do not plug in electrical items when hands are wet.
11. Clean up work areas and equipment at the end of the work period. Return all tools, clean and in working order, to the proper storage area.

1.6 Supplemental Resources for Safety Unit (continued)

12. Understand how a tool works and what its proper usage is. If a tool or equipment is not functioning the way it is supposed to, stop and report it to the teacher immediately.
13. Report any accident (fire, spill, breakage, etc.), injury (cut, burn, etc.), or hazardous condition (broken equipment, etc.) to the teacher IMMEDIATELY.
14. When carrying an over-sized or dangerous item from one place to another, warn others loudly so they will avoid being injured as you pass.
15. Do not take or remove tools, equipment, supplies, or parts from the Greenpower Lab without permission from the teacher.
16. DO NOT HANDLE THE CAR'S BATTERIES AT ALL. This is the job for the instructor.

Signing below indicates you will abide by the above safety rules.

Signature of student: _____

Date: _____

Signature of Parent or Guardian: _____

Date: _____

1.6 Supplemental Resources for Safety Unit (continued)

Printed Student Name: _____

Greenpower Build Safety Test

DIRECTIONS: Write “True” or “False” in the blanks next to each question to decide which safety rules are right or wrong.

- _____ 1) Horseplay, practical jokes, and pranks will be tolerated. Running, skipping, hurrying or touching each other is encouraged.
- _____ 2) Pay full attention to the task you are doing. Concentrate. Do not interrupt or disturb others who are concentrating on their task.
- _____ 3) Do not follow all written and verbal instructions. Do not ask your teacher questions if you do not understand the instructions.
- _____ 4) Food and drinks are allowed in the Greenpower Lab.
- _____ 5) Dress properly—long hair must be tied back, no dangling jewelry (necklaces, earrings, lanyards...), and no loose or baggy clothing. Closed-toed shoes are a must!
- _____ 6) Know where the exits are located and what to do in case of an emergency or fire drill.
- _____ 7) No safety glasses or goggles are needed.
- _____ 8) Keep your work area and the Greenpower Lab neat and clean. Only have necessary items in the area.
- _____ 9) You can retrieve any tools, equipment, supplies, or other materials in the Greenpower Lab or the storage closet without permission from the teacher.
- _____ 10) Do not plug in any electrical item with wet hands.
- _____ 11) Do not clean up all work areas and equipment at the end of the work period. Leave all tools in a mess and unorganized.
- _____ 12) Understand how a tool works and the proper use of it before beginning. If a tool or equipment is not functioning the way you think it is supposed to, stop and report it to the teacher immediately.
- _____ 13) There is no need to report any accident (fire, spill, breakage, etc.), injury (cut, burn, etc.), or hazardous condition (broken equipment, etc.) to the teacher.

1.6 Supplemental Resources for Safety Unit (continued)

- _____ 14) If you are carrying an over-sized or dangerous item from one place in the room to another, warn others loudly so they will avoid being injured as you pass.
- _____ 15) You can take or remove tools, equipment, supplies, or parts from the Greenpower Lab without permission from the teacher.
- _____ 16) Irresponsible handling of batteries can result in personal injury.

1.6 Supplemental Resources for Safety Unit (continued)

MEDIA CONSENT AND RELEASE FOR A MINOR

(Print Student's Name)

I hereby grant consent, authority, and permission to **(insert organization here)**, and to those acting with the authority associated with this entity, to use, reuse, publish, republish, the name, statements or comments, likeness, picture, photographic image, or videotape or electronic image, or videotape or electronic image of the minor (under the age of 19 years) below, in whole or in part, or composite or distorted, without restriction as to changes or alterations, without prior approval, in conjunction with original or reproductions in color or otherwise, in printed or electronic form, made through any medium or media, for illustration, promotion, advertising, trade, or any other purpose whatsoever.

I understand and agree that I will not receive any compensation for the use consented to herein. I hereby release, and discharge all persons acting under the consent granted above from all liability, cause of action or claim civil or criminal, by virtue of any distorted or use, intentional or otherwise, that may occur or produced in the taking or subsequent processing or publication of my name, statements, comments, or the images covered herein.

I hereby warrant that I am of legal age and have the right to contract, consent, or grant release for the minor in the above regard. I also warrant that I have read the above consent and release, prior to its execution, and that I am fully familiar with the contents thereof. This consent and release shall be binding upon me, my heirs, legal representatives and assigns.

SIGNATURE OF WITNESS

PARENT/GUARDIAN/CUSTODIAN
SIGNATURE

DATE

DATE

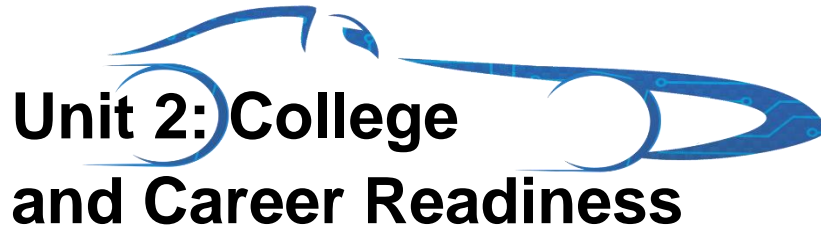
MINOR

DATE

1.7 Teacher Recommendations

The test can be administered on-line with Web 2.0 tools such as Socrative, Survey Monkey, Quizlet. Kahoot and Quizizz can be used to drill students about safety situations.

- <http://www.socrative.com/>
- <https://www.surveymonkey.com/>
- <https://quizlet.com/>
- <https://getkahoot.com>
- <http://quizizz.com/>

The logo features a stylized blue graphic of a pen nib or quill, with a circular element that resembles a lens or a stylized letter 'C'. The text 'Unit 2: College and Career Readiness' is written in a bold, black, sans-serif font, with the '2' in 'Unit 2' being significantly larger and partially overlapping the blue graphic.

Unit 2: College and Career Readiness

2.1 Reference Standards

Note that these standards will be applied throughout this unit. For the complete standard, please see Appendix A.

Language Standards

- L6-8.1, L9-10.1 (Demonstrate command of English grammar)
- L6-8.2, L9-10.2 (Demonstrate command of punctuation)
- L6-8.3, L9-10.3 (Use knowledge of language and its conventions in writing, speaking, reading, and listening)

Writing standards

- W6-8.1, W9-10.1, CCRASL-W1 (Write arguments to support claims)
- W6-8.2, W9-10.2, CCRASL-W2 (Write informative or explanatory text to convey concepts)
- W6-8.4, W9-10.4, CCRASL-W4 (Produce clear and coherent writing)
- W6-8.5, W9-10.5, CCRASL-W5 (Develop and strengthen writing by editing)
- W6-8.6, W9-10.6, CCRASL-W6 (Utilize technology to produce and publish writing)
- W6-8.9, W9-10.9, CCRASL-W9 (Draw evidence to support writing)
- W6-8.10, W9-10.10, CCRASL-W10 (Write routinely for discipline-specific purposes)

Speaking and Listening Standards

- SL6-8.1, SL9-10.1 (Engage in collaborative discussions)
- SL6-8.4, SL9-10.4 (Present claims in a coherent manner)
- SL6-8.5, SL9-10.5 (Integrate multimedia to clarify information)
- SL6-8.6, SL9-10.6 (Adapt speech to a variety of contexts)

Math Standards

- 6NS.1 (Divide multi-digit numbers)
- 6NS.2 (Add, Subtract, multiply, and divide multi-digit decimals)
- AC-7 (Use analytical, numerical and graphical methods to make financial decisions)

Technology Education Standards (Alabama)

- TE6-8.5 (Use basic features of productivity software)
- TE6-8.6 (Use digital tools for completing tasks)
- TE6-8.8 (Social networking and electronic communication)
- TE6-8.9 (Responsible and legal use of technology systems and digital content)
- TE6-8.11, TE9-12.12 (Use digital tools to synthesize information)
- TE9-12.5 (Use advanced features of spreadsheets)
- TE9-12.6 (Multimedia presentations)
- TE9-12.8 (Safe use of social network and electronic communication)
- TE9-12.9 (Ethical and legal use of technology systems and digital content)

- TE9-12.11 (Assess validity of Web content)
- TE9-12.16 (Create products that integrate info from multiple software applications)

Reading Standards

- CCRASL-R1 (Cite evidence to support analysis of science and technical text)
- CCRASL-R7 (Integrate quantitative or technical information visually)

Career and Technical Education Standards (Alabama)

Sales and Promotion

- CTE S&P 9-12.4 (Design ad campaign for target market, prepare budget, set timeline)

STEM Foundations of Engineering

- STEM FE 9-12.1 (Resumes and Job applications)

2.2 Introduction to Professional Communication

In this unit, the primary focus is professional communication, with an emphasis on conveying information verbally and nonverbally. Greenpower is a program in which communication skills are needed to deliver information that informs, promotes, and documents activities or performance. All of these components reflect communication involved in real-world engineering projects.

Objectives

In this unit, the students will:

- Apply for a team position by:
 - Writing a resume
 - Filling out a job application
 - Performing a mock interview
 - Dressing appropriately for a job interview
- Create a presentation for prospective sponsors by:
 - Developing a business plan
 - Establishing a marketing strategy
 - Creating a budget
 - Creating a visual presentation tool
- Effectively present information pertaining to the Greenpower Program
 - present all team members and their duties
 - introduce the car, its design and modifications
 - define the activities and events completed or planned for the team
 - present your business/financial plan and a marketing strategy

Key Vocabulary

- Application
- Budget
- Business/Financial Plan
- Marketing Strategy
- Personal References
- Resume

Pacing

You will need approximately 2 weeks to complete the basics of this unit with some activities continuing as other build units begin. Work on the race event presentation and fundraising will continue throughout the entire program

2.2.1 Supporting Activities

My First Resume (L6-10.1,2,3; W6-10.4,5,6,10; TE6-8.5,6; CTE FE9-12.1)

- Have students write their own resumes. The following website is a good resource: <https://www.careerkids.com/MyFirstResume.aspx>. A PDF version of this can be downloaded from the website. If the document needs editing, try using an online PDF to Word converter.
- Students will address their interests, goals, responsibilities, current jobs, and any skills or achievements.

Apply for the Job (L6-10.1,3; W6-10.1,4,5,6,10; SL6-10.4,6)

- See resources at lesson plan sites such as <http://www.scholastic.com/teachers/lesson-plan/applications-and-interviews>.
- Role play interviews.
- Fill out mock job applications.

What Does Your Appearance Say About You? (SL6-10.4,6)

- Discuss how someone is treated in public when dressed professionally versus being dressed poorly. Have students dress as professionally as possible and observe how they are treated. Later, the students will dress unprofessionally (within school dress code policies) and observe how they are treated. The students can write a reflection about their observations.
- Find pictures portraying candidates for a job. Ask the students who they would pick for various job titles. For example, ask the class “You are interviewing applicants for an accountant position? Which of these two is more likely to be hired?”

How Do I Market It? (W6-10.1,4,5,6,9; CCRASL-R1,7; SL6-10.1,4,5; TE6-8.5,6,8,9; TE9-12.5,6,8,9,16; CTE S&P9-12.4)

- Create visual presentations, both physically and digitally, that can be presented to the community to gain community awareness and support.
 - Flyers
 - Business Cards
 - Brochures
 - Websites (Blogging)
 - Social Media
- Explore presenting a “sales pitch” verbally; consider watching clips from a television show like “Shark Tank” and discuss why certain people are successful.
 - The premise for this particular television show is for entrepreneurs to present a product or idea to a group of investors. Based on their “sales pitch”, the investors decide if they want to be a business partner or not.
- Brainstorm ways to recognize donors/sponsors.

Money Matters (6NS.1,2; AC-7; CCRASL-R7, TE6-8.5,6,11; TE9-12.5,14)

- Explore the basics of creating and managing a budget for the Greenpower program.

- Look at various methods for raising money such as soliciting, prize drawings, and sales of goods for profit.
- Create an Excel budget to fit in the business plan that will be presented at races and to prospective sponsors.

Presentation 101 (SL6-10.1,4,5,6; TE6-8.5,6,11; TE9-12.6,16)

- Have students present, individually or in groups, information about their personal interests (music, sports, etc.). Include the following presentation components:
 - Inflection
 - Pronunciation
 - Clarity
 - Assertiveness
 - Rhythm
 - Audience

Get to know us/Support our team! (SL6-10.1,4,5,6; TE6-8.5,6,8,11; TE9-12.5,6,8,9,16)

- Students introduce the team and present information about the car at a community or race event to solicit support. This presentation should be well rehearsed and include a technology component.
 - Each team member introduces himself/herself and defines his/her duties.
 - Introduce the car, the basis for its design and modifications made or planned.
 - Present the business/financial plan and marketing strategy, detailing past successes and future events.
 - Define any additional activities and events completed or planned for the team.
 - Be prepared to answer questions intelligently about the car, ie. design, functions, and reasons behind changes/decisions the team implemented.

Letter to My Future Self (L6-10.1,2,3; W6-10.1,2,4,5,6,9,10)

- This unit is a good place for the student to insert a summary style assignment in their engineering notebook. Students describe the Greenpower project and the functions of team members. This activity provides an opportunity for reflection later in the year (section 9.6). Students compare their initial concept to the finished project

2.3 Team Structure

The Greenpower project can easily be divided into groups or subgroups with a central focus. Below is a recommended list of positions for the team. Students can apply needed skills from section 2.2 to apply for these positions. It is recommended that the group participate in team-building activities prior to selecting members for specific positions. This allows all members to see how each other works in different situations. Some students may hold more than one position.

Suggested Roles

- Manager/Team Lead
- Safety Manager
- Public Relations Manager
- Materials Manager
- Build Team Leader
- Data Manager
- Driving Team
- Pit Chief

2.3.1 Manager/Team Lead

This position is held by a team member who will oversee all aspects of the program. This person will make final decisions that benefit the team. He or she needs to be assertive, responsible, mature and respected, and demonstrates exceptional leadership qualities and skills. All subgroups report to the Team Lead for final project approval.

2.3.2 Safety Manager

This position is held by a team member who understands the importance of safety procedures. He or she will be in charge of all aspects of safety throughout the entire Greenpower process (pre-build, build, driving and pit stops). This person will need to anticipate dangerous situations, prepare for them, and respond appropriately in the event of an accident.

2.3.3 Public Relations Manager

This position is held by a team member who is organized, presents him/herself well, and can communicate with anyone. This person oversees the Public Relations Committee and makes sure all required documentation is completed for race events. The Public Relations Committee will focus on the following areas:

- Fundraising
 - Needs to be creative, resourceful, innovative
- Budgeting
 - Needs good math and problem solving skills
 - Good organizational skills are strongly recommended
- Communications/Correspondence
 - Needs good writing and language skills
- Promotions/Marketing (team logo, t-shirts, advertising. etc.)
 - Shows initiative and resourcefulness
 - Organizes events to help with fundraising

2.3.4 Materials Manager

This position is held by a team member who is organized, reliable, conscientious, and communicates well. This person is in charge of tools, car parts and equipment. He/she will be responsible for checking out/in all equipment. They must inventory and always know the whereabouts of all items. This person is also responsible for making sure the necessary equipment is available on location for various events.

2.3.5 Build Team Leader

This position is held by a team member who understands every aspect of the car. He or she will make sure that all technical regulations are met for scrutineering. This person needs to demonstrate the following characteristics:

- Team Player
- Effective Planner
- Can read and follow instructions
- Attentive to details

- Good Problem Solver
- Take initiative

This person will also oversee build teams responsible for:

- Body Design
- Tires and Brakes
- Steering
- Drive Assembly
- Electrical Components

2.3.6 Data Manager

This position is held by a team member who manages all data collected during driving time. This person needs to exhibit proficient computer skills that include the use of Excel formulas and data entry. He/she will be responsible for displaying a visual representation of the collected data and facilitate discussions about analyzing the data.

2.3.7 Driving Team

This position is for team members who are interested in driving the car. These team members need to be comfortable driving the car and are able to think clearly in racing conditions. How a particular driver affect's the car's performance needs to be taken into account when choosing drivers.

2.3.8 Pit Chief

This position is a team member who is responsible for all aspects of pit changes during racing events. This person will oversee the Pit Crew and understand procedures that happen during a pit change. A Pit Crew should consist of:

- Person to push the car through Pit Row
- Team Lead
- Build Lead
- Drivers (three)
- Safety Manager

2.3.9 Supporting Activities

Team Building Activities

- Activities should focus on cohesiveness, communication, trust, and utilizing team members' strengths. The following website are good resources:
- <http://www.teachthought.com/teaching/10-team-building-games-that-promote-critical-thinking/>
- <http://www.onlineexpert.com/elearning/user/pdf/natsem/managingdiverseworkforce/team-buildinggamesactivitiesideas.pdf>

2.4 Teacher Recommendations

- Students should “try out” for various positions before applying. This gives them the opportunity to see if the position is what they expect it to be.
- Once tryouts are completed students work on resumes that are tailored to team positions.
- Team size is an important consideration. Teams that are too small or too large can be ineffective. If a team is too small individual team members can become overloaded. If a team is too large there will be times when students are looking for things to do.



Unit 3: Getting Started: Tools and Body Basics

3.1 Reference Standards

Note that these standards will be applied throughout this unit. For the complete standard, please see Appendix A.

Writing Standards

- W6-8.1, W9-10.1, CCASL-W1 (Write arguments to support claims)
- W6-8.2, W9-10.2, CCASL-W2 (Write informative or explanatory text to convey concepts)
- W6-8.4, W9-10.4, CCASL-W4 (Produce clear and coherent writing)
- W6-8.5, W9-10.5, CCASL-W5 (Develop and strengthen writing by editing)
- W6-8.6, W9-10.6, CCASL-W6 (Utilize technology to produce and publish writing)
- W6-8.7, W9-10.7, CCASL-W7 (Conduct research projects)
- W6-8.8, W9-10.8, CCASL-W8 (Gather and summarize relevant, credible information)
- W6-8.9, W9-10.9, CCASL-W9 (Draw evidence to support writing)
- W6-8.10, W9-10.10, CCASL-W10 (Write routinely for discipline-specific purposes)

Speaking and Listening Standards

- SL6-8.1, SL9-10.1 (Engage in collaborative discussions)
- SL6-8.3, SL9-10.3 (Evaluate reasoning and relevance of claims)

Reading Standards

- CCASL-R5 (Analyze relationship among concepts/key terms presented in text)
- RI6-8.8, RI9-10.8, CCASL-R8 (Evaluate text for reasoning and relevance)
- RI6-8.9, CCASL-R9 (Analyze conflicting information on the same topic)

Math Standards

- 6RP.3 (Use ratio and rate reasoning to solve real-world problems)
- 7EE.3 (Solve multi-step real-life problems strategically)
- 7G.1 (Solve problems involving scale drawings)
- 7G.3 (Describe two-dimensional figures from slices of three-dimensional figures)
- 7G.6 (Solve real-world problems involving surface area)
- G-CO12 (Make formal geometric constructions)

Science Standards

Physical Science (8th)

- PS8.8 (Identifying Newton's Three Laws of Motion)
- PS8.9 (Simple Machines)

Technology Education Standards (Alabama)

- TE6-8.5 (Use basic features of productivity software)
- TE6-8.11, TE9-12.12 (Use digital tools to synthesize information)

- TE9-12.9 (Ethical use of digital content)
- TE9-12.11 (Critique digital content for accuracy, bias, currency, relevance)
- TE9-13.14 (Use digital tools to defend solutions)
- TE9-12.16 (Use charts in presentations)

3.2 General Overview

In this unit, students become familiar with tools needed to build the car and the basics of the body design process. More specific design activities will be addressed in Unit 8. The Formula 24 kit car is a welded steel tube spaceframe to which the floorboard and all other components are added. The floorboard will be one of the first steps in the physical construction of the car. The aerodynamic design research and body creation will occur concurrently with other build activities.

Objectives

In this unit, the students will:

- Select and use appropriate tools required for assembly.
- Install the floorboard to the spaceframe chassis.
- Explore different types of framework in various automobiles.
- Understand and find measurements using a caliper.
- Define vocabulary terms that pertain to the design of automobiles.
- Explore and understand orthographic projections as applied to body design.
- Collaborate to design the outer shell of the race car.
- Research aspects of aerodynamic flow.
- Apply aerodynamic design to create a physical model.
- Become familiar with the metric and US units of measurement.

Key Vocabulary

- Aerodynamics
- Car Body
- Chassis
- Elevations
- Orthographic Projection
- Scribe (similar to score or lightly mark)

Pacing

Allow approximately 1 week to complete the build activities in this unit.

3.3 Materials and Tools

Table 3.3 Floorboard Assembly Materials and Tools

Tool	Description
Safety Glasses	Always wear safety glasses when working around the car
Permanent Marker	Mark the layout of holes to be drilled in the aluminum floor
Hammer	Tap the center punch to mark the centers of all holes to be drilled (floor and chassis)
Center Punch	Mark the center of the holes to be drilled (floor and chassis)
Clamps	Securely attach floor to chassis in correct orientation before drilling holes in the Chassis
Hand Drill	Drill holes in the floor and chassis for the Pop Rivets
#30 Drill Bit (3.3 mm)	Drill holes in the floor and chassis for the Pop Rivets
Pop Rivet Hand Tool	Used to install the Pop Rivets through the floor and into the chassis
Saw horse/table	Place the car on the saw horses/table during construction and modification
Strapping material (optional)	Use to secure the car frame to the saw horses

3.4 Unit Procedures

3.4.1 Tool Basics

Procedure

Students will handle and experiment with each tool listed below. They will be able to identify each tool by name, understand its purpose, appropriate use, and application. **REMEMBER: SAFETY FIRST!**

- Crescent wrench
- Socket wrench
- Rivet gun
- Screwdrivers - both flathead and phillips head
- Pliers
- Drill
- Clamp

- Hammer
- Saw
- Allen keys/wrench
- Volt meter

3.4.2 Installing the Floorboard

Table 3.4.2 Floorboard Installation Parts

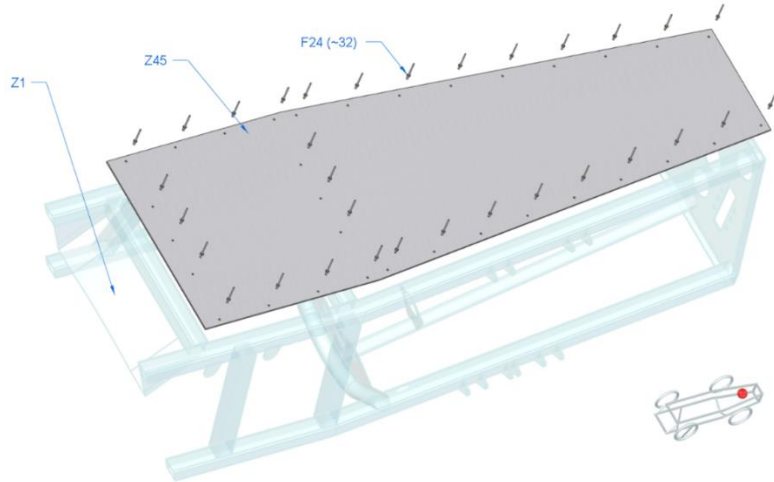
Part Number	Quantity	Description
Z1	1	Chassis
Z45	1	Floor
F24	32*	M3.2 x 10mm Pop Rivet (*approximate based on layout).

Procedure

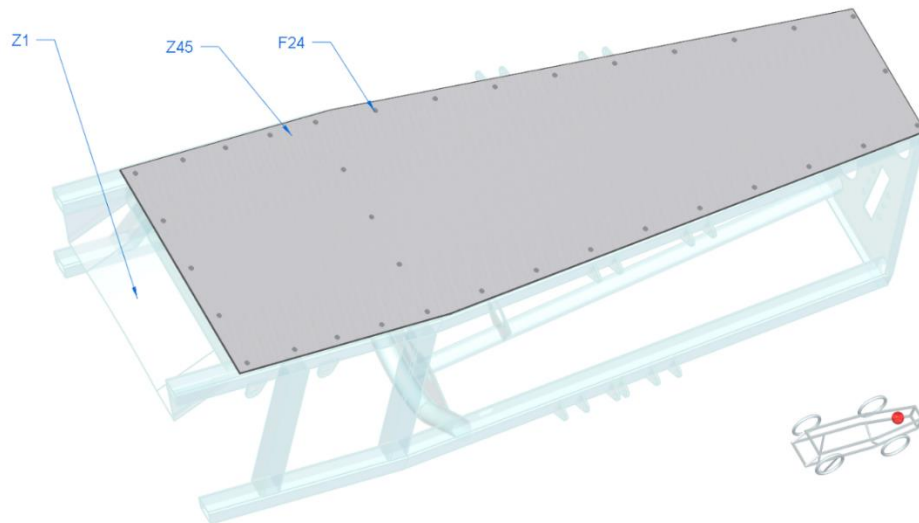
BEFORE INSTALLING YOUR FLOORBOARD, MAKE SURE EVERYONE IS WEARING SAFETY GLASSES! If your floorboard does not arrive pre-drilled, you will need to follow steps 1-8 to determine placement of floorboard holes.

1. Safety recommendation: Place the car on saw horses and tether the car frame to the saw horse with straps when completing this and other sections of car construction or modification. In this particular case, the car will be upside down.
2. Using a caliper, measure the width of the tube of the bottom of the car's frame.
3. Determine where the center of the tube is located and set your caliper to that distance. (See Caliper Activity "*And the Caliper says...*" on page 26 for help with this step.)
4. Once the distance is set on the caliper, scribe a line all the way down both sides of the floorboard to give a visual location for the rivets.
5. Repeat Steps 2 and 3 for the ends of the floorboard.
6. After the lines are scribed on the floorboard, measure 100mm (approx. 4 inches) apart and place marks to give precise location for each rivet. Establish a pattern that works for your car.
 - i. Discuss with the team ways to make efficient use of the rivets.
 - ii. Consider areas that may require more/less rivets to support the local load.
 - iii. The seat may require more rivets than the leg area.
 - iv. Complete an activity to investigate the relationship between Metric and English units.
7. Using clamps, secure the floorboard to the frame of the car.
8. Using a center punch, punch a dent into the floorboard at each mark from step 5. This will help make sure your drill does not move while drilling the holes.

9. Using a power drill with a (#30) 3.3 mm or equivalent ($\frac{1}{8}$ inch) drill bit, drill through the floorboard and frame at each rivet location. It is recommended to drill the hole and then place the rivet before moving on to the next rivet location.
10. To place the rivet, use a Pop Rivet gun to secure the rivet in place.
11. Continue Steps 8 and 9 until all rivets are in place and the floorboard is secured to the frame.



**3.4.2.1
Floorboard (Unassembled)**



**3.4.2.2
Floorboard (Assembled)**

3.5 Supporting Activities

Use the right tool for the right job (PS8.9)

- Students should research each tool needed for the build process and list all of the simple machine components/functions involved.

- This activity will be a continuous process during the build. As a new tool is introduced, the student should identify its mechanical advantage and what can be gained by the use of the tool.

And the Caliper says... (W6-8.8, W9-10.8, CCRASL-W8, 7EE.3, G-CO12)

- Students watch a video about reading a caliper. The following is an example video <https://www.youtube.com/watch?v=7-6ALptqQQ>.
- Using a collection of items (wood blocks, books, drinking glasses...) measure inside and outside, then create a list of measurements to compare with other students.
- Student should document this activity in written form, with clarity, perhaps as a lab report.
- Students can measure and translate dimensions of circular objects or openings into an engineering drawing of a car component (e.g. rear axle support, bearings) using hand drawing tools or CAD software, such as Siemens Solid Edge.

Metric vs English, the Epic Battle (7EE.3)

- Students take measurements of classroom objects in both centimeters and inches to become familiar with the relationship.
- Students use the measurements made in inches, convert them to centimeters using standard formulas and then compare those to the measurements made.
- Students explore conversions between various units within the same system (inches to feet, centimeters to millimeters) to understand their relationships. Especially important is understanding millimeters since many items in this build use millimeters, including tool and bolt sizes.
- Explore the dimension unit options available in CAD software such as Siemens' Solid Edge.

Vantage Point (SL6-8.1, SL9-10.1, 7G.3)

- Review orthographic projection concepts used in technical drawings. The following video provides an excellent explanation: http://www.engineeringessentials.com/ege/ortho/ortho_page1.htm
- Using a model of any vehicle, have students draw the 6 different views (front, top right, left, bottom, back).
- Give the students a front, top and side view image of a model toy block configuration and have them recreate a 3-dimensional model. This activity can be done individually or in groups, on paper or in 3D modeling software.
- Using drawing tools and paper, create a scale model of the wheel hub (Z26) in 3 views, front, top, and side, then create the item in CAD software, such as Siemens' Solid Edge and check the accuracy of your views. This can be tied into a Geometry lesson on translations and transformations if the part involves copy and reflecting a feature over a center line

Automobile Frames (W6-8.1,8; W9-10.1,8; CCRASL-W1,8; TE6-8.5,11; TE9-12.9,12)

- Research various types of vehicle frames. This information helps students understand the use of the space frame in this application. Key search terms should include: space frame, unibody, body-on-frame, monocoque.
- Students present examples of various body types that they find in their research.

My Proposed Design (W6-8.1,6,7; W9-10.1,6,7; CCRASL-W1,6,7; RI6-8.8,9; RI9-10.8,9; CCRASL-R8,9; SL6-8.1,3; SL9-10.1,3)

- Use Padlet, Trello or other online collaboration sites where students post design sketches/ideas and give and receive feedback. Students should be able to defend their concept with references to researched information.
- Students should consider the availability and cost of materials in their design and make sure all Greenpower USA Technical Regulations are met. See GreenpowerUSA.net.

Aerodynamics (W6-8.7,8; W9-10.7,8; CCRASL-W7,8; SL6-8.1,3; SL9-10.1,3; 7G.6; PS8.8; TE6-8.5,11; TE9-12.9,12,14,16)

- Students need to research and understand what makes an object more or less aerodynamic. Students can collaborate with a partner and present to the team, using graphs, pictures, and other pertinent information, what they learn.
- Students can design a scale model nose for the F24 then test the design for aerodynamics. Models can be shaped of clay, carved of foam or designed in CAD software such as Siemens' Solid Edge then printed. Testing can be completed in a wind tunnel or, for the CAD, simulator software. If neither is available, students discuss the aerodynamic pros and cons of each design.
- Building a wind tunnel is an excellent investigative tool for aerodynamics. Simple wind tunnels can be created using readily available items. An example set of videos are: https://www.youtube.com/watch?v=i0Q0nx0_Dgc <https://www.youtube.com/watch?v=620ex2qivDs> .

NOTE: THIS ACTIVITY SHOULD BE COMPLETED WITH TEACHER SUPERVISION DUE TO THE USE OF FIRE/SMOKE AND SHARP CUTTING TOOLS.

And the Winner Is? (SL6-8.1; SL9-10.1; 6RP.3; 7G.1; PS8.8)

- Have students build model cars (such as Pinewood Derby Cars, Technology Student Association CO2 dragsters...) and race them to determine the best aerodynamic design.

You see, it's like this... (W6-8.1,2,4,5,8,9,10; W9-10. 1,2,4,5,8,9,10; CCRASL-W1,2,4,5,8,9,10)

- Several of the supporting activities in section 3.5 provides excellent places for a writing extension. Students can define various automobile frame types and give supporting information about their strengths and weaknesses. Aerodynamics can be defined as it applies to the body design of this car. As an extension students can defend a body design they are proposing. Any of these activities make an excellent entry in their engineering notebook.

3.6 Teacher Recommendations

- For ease of access, the space frame could be strapped across a pair of sawhorses during the entire build process.
- As students work, a small brush to sweep up metal shavings should be used. A shop vacuum is a great tool for cleaning up messes.
- Tool usage should be considered as one of the most dangerous aspects of the build. If unsure about the proper use of a tool, research it or invite a knowledgeable guest to assist. If students or the lead teacher are unfamiliar with the operation of a certain tool, do not proceed until knowing how to use the tool properly.
- Throughout the build process, enlisting the help of engineers and other technical specialists is a great idea. They have knowledge about tools and techniques that will help with the build.
- Determining the best location of the corner rivet can be geared as a lesson in bisecting angles.



Unit 4: Steering and Brake Assembly

4.1 Reference Standards

Note that these standards will be applied throughout this unit. For the complete standard, please see Appendix A.

Writing Standards

- W6-8.2, W9-10.2, CCRASL-W2 (Write informative or explanatory text to convey concepts)
- W6-8.4, W9-10.4, CCRASL-W4 (Produce clear and coherent writing)
- W6-8.5, W9-10.5, CCRASL-W5 (Develop and strengthen writing by editing)
- W6-8.8, W9-10.8, CCRASL-W8 (Gather and summarize relevant, credible information)
- W6-8.9, W9-10.9, CCRASL-W9 (Draw evidence to support writing)
- W6-8.10, W9-10.10, CCRASL-W10 (Write routinely for discipline-specific purposes)

Reading Standards

- RI6-8.4, RI9-10.4, CCRASL-R4 (Determine the meaning of words used in text)
- CCRASL-R3 (Following Multistep procedures in technical measurements and tasks)
- CCRASL-R4 (Determining meaning of symbols, terms and words in technical context)
- CCRASL-R5 (Analyze relationship among concepts/key terms presented in text)

Math Standards

- 6EE.9 (Use variables to represent 2 quantities that change in relationship to one another)
- 7EE.4 (Use variables to represent quantities in a real-world problem)
- 7G.2 (Draw geometric shapes with given conditions)
- 7G.4 (Area and Circumference of a circle)
- 7G.5 (Use facts about angles to solve simple equations for an unknown angle)
- 7G.6 (Real-world problems involving shapes)
- 8G.5 (Angles created when parallel lines are cut by a transversal)
- 8SP.3 (Interpreting bivariate measurement data)
- A-CED2 (Equations in 2 or more variables to show relationships)
- F-IF4 (Interpret key features of a graph modeling relationship between two quantities)
- AC-5 (Determine rate of change from graphical and numeric data)

Science Standards

Physical Science (8th)

- PS8.8 (Newton's three laws of motion)
- PS8.9 (Mechanical advantages of simple machines)
- PS8.10 (Potential versus kinetic energy)
- PS8.11 (Effects on electric forces)

4.2 General Overview

During the build phase of this unit, students will install the components that make up the steering and brake assembly. This includes the wishbone, steering column, steering linkage, tires, and brake assembly. In the post-build phase, students will experiment with toe and camber changes, adjusting them to get desired car performance. GreenpowerUSA's website has videos that will assist in understanding these components and how adjustments can be made. See GreenpowerUSA.net.

Objectives

In this unit, students will:

- Understand a vehicle wheel and axle and its structure.
- Understand the Ackermann Geometry of the car.
- Understand the interaction of the parts of various steering systems.
- Install the steering components.
- Understand different types of brakes and the forces, energy and friction involved.
- Assemble and install the F24 front brakes.
- Complete the brake system by installing the cables.
- Adjust the brakes properly to reduce friction.
- Adjust toe and camber of the vehicle to the desired position.

Key Vocabulary

- Ackermann Steering Geometry
- Air pump
- Allen Key/Wrench
- Stub Axle
- Brake Caliper
- Camber
- Crescent Wrench
- Disc Brake
- Drag Link
- Friction
- Mechanical advantage
- Nyloc
- Pressure gauge (tire)
- Set screw
- Socket Wrench
- Tie Rod
- Toe
- Washer

Pacing

Allow approximately 3 weeks to complete the build activities in this unit.

4.3 Materials and Tools

Table 4.3 Tire and Brake Assembly Materials and Tools

Tool	Description
Safety Glasses	Always wear safety glasses when working around the car.
Air Pump	To pump up the tires
Air pressure Gauge	To measure the tire pressure
Rubber Mallet	To assist with inserting bolts into holes tight with powder coat
Tire Levers	To assemble the tire onto the rim
Hex/Allen Key Wrenches	For the bearing set screws, Socket Head Screws, and Steering Wheel Hub set screws
Brake Tool	To cut excess brake cable
Permanent Marker	To mark the cut locations on the Steering Connecting Rod
Hacksaw	To cut Steering Connecting Rod (Z13).
File	To clean up the ends of the Steering Connecting Rod (Z13) after being cut.
Screwdrivers	As needed
8mm Wrenches/sockets	Two required to assemble the Nyloc Nuts onto the cap screws
Meter or Yardstick	For measuring while adjusting Toe and Camber

4.4 Unit Procedures

4.4.1 Installing Wishbone Assembly

Table 4.4.1 Wishbone Assembly parts

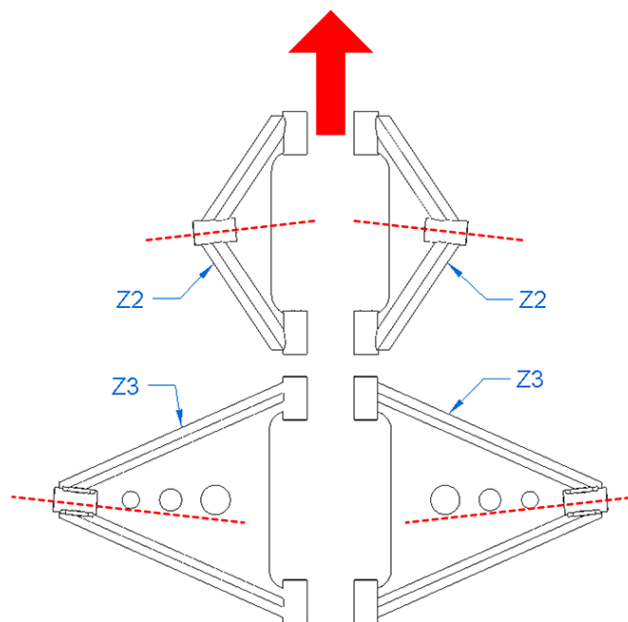
Part Number	Quantity	Description
Z2	2	Upper Wishbone (observe correct orientation)*
Z3	2	Lower Wishbone (observe correct orientation)*

F17	8	M8 x 50mm Cap Screw
F13	8	M8 Nyloc Nut
Z5	2	Stub Axle Bracket (right and left)*
Z6	4	Tie Rod End Male
F10	8	M8 Washer
F11	2	M8 Nylon Washer
F13	8	M8 Nyloc Nut
F14	8	M8 Nut
F16	8	M8 x 30mm Cap Screw
Z4	2	Torsion Rod
Z6	4	Tie Rod End Male

* Note that parts Z2, Z3 and Z5 are specific to the left and right sides.

Procedure

1. Assemble the wishbone and stub axle brackets onto the front of the car as shown in Figure 4.4.1.1. Make sure the wishbones and axle brackets are installed on the appropriate sides of the vehicle. Using the illustration below make note of the slight angular difference in the left and right side pieces. The red arrow points to the front of the car.



Due to the powder coating after manufacturing, it may be necessary to clean out the holes to get the bolts through. You can ream the holes out using a drill bit. If needed, a rubber mallet can be used to lightly tap the bolts into place. Use caution to not damage the threads of the screw. Not all of the parts will be completely tightened until all components are at the desired position. This can be completed after installing the steering mechanism.

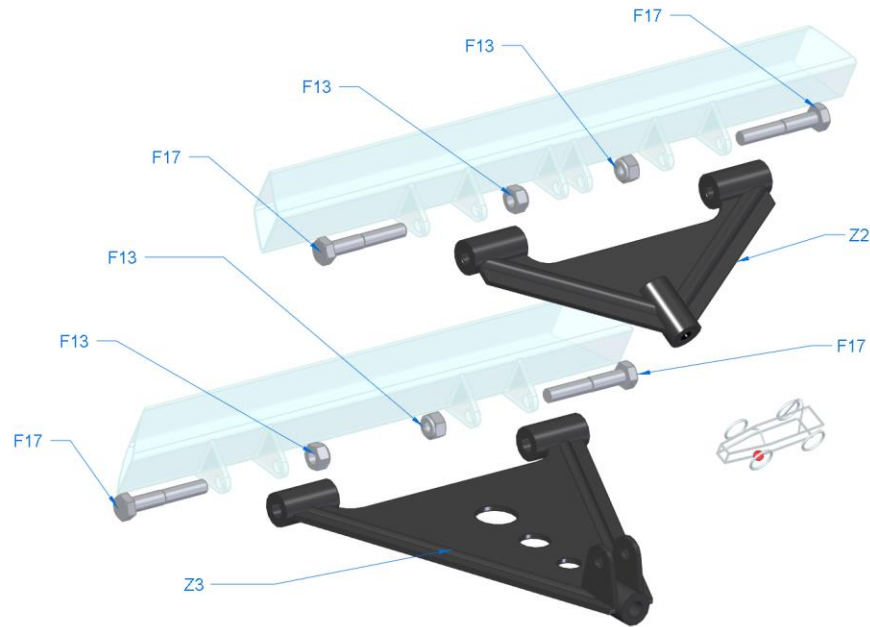
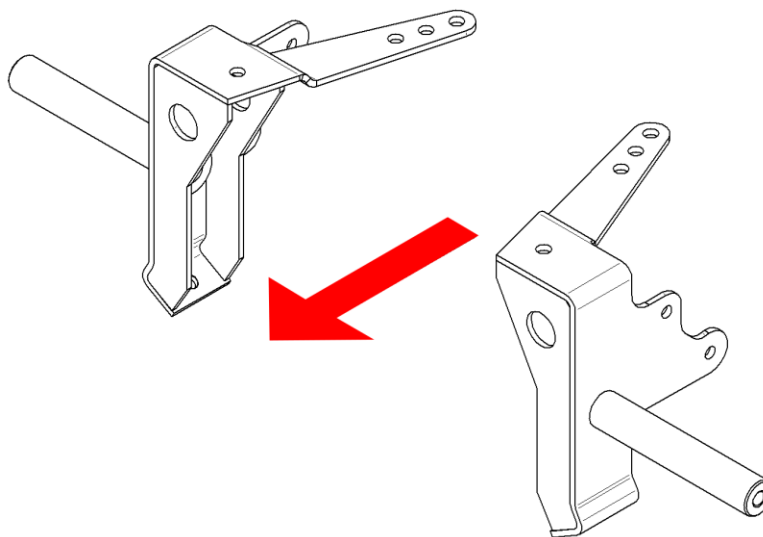
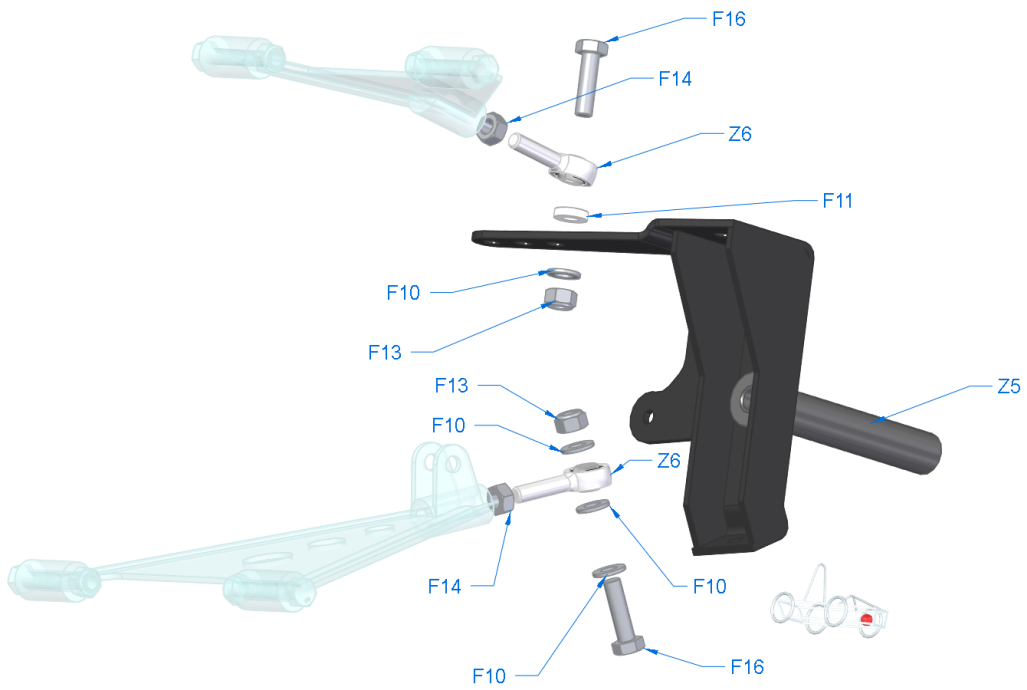


Figure 4.4.1.1
Wishbone – Left (Unassembled)

2. Next install the stub axle brackets Z5 noting the orientation for left and right sides in Figure 4.4.1.2. Figures 4.4.1.3 and 4 show the assembly for the left side.



**Figure 4.4.1.2
Front Stub Axle Bracket Orientation**



**Figure 4.4.1.3
Left Stub Axle Bracket (Unassembled)**

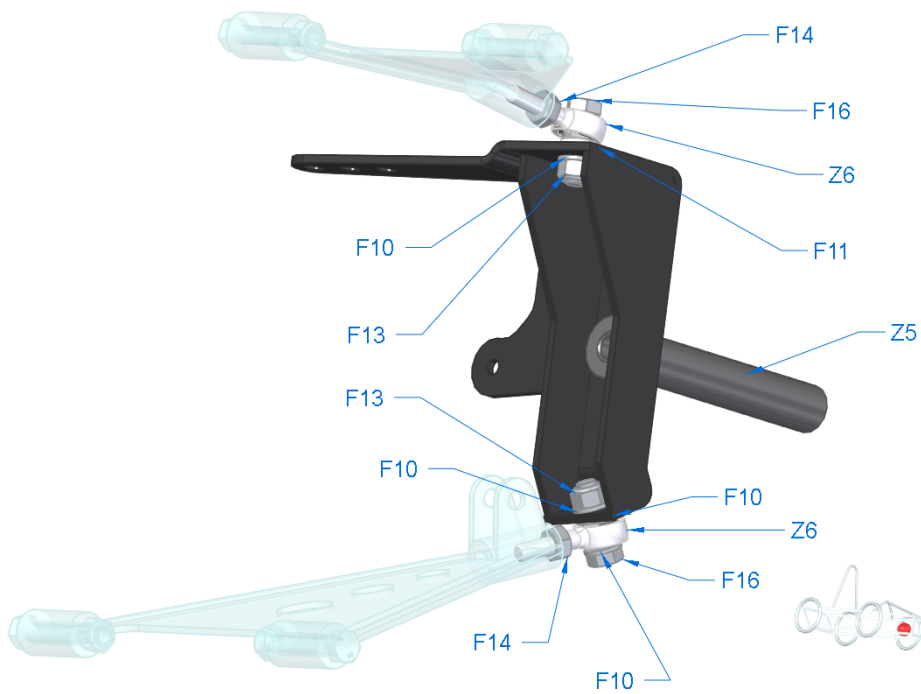


Figure 4.4.1.4
Left Stub Axle Bracket (Assembled)

3. The Torsion rod Z4 is inserted between the angle bracket as shown in Figures 4.4.1.5 and 6.

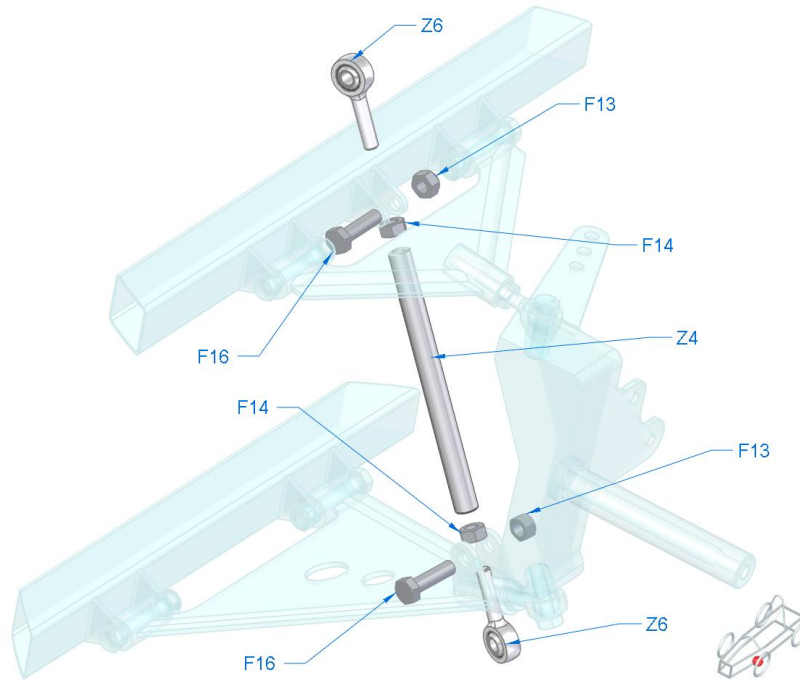


Figure 4.4.1.5
Torsion Rod - Left (Unassembled)

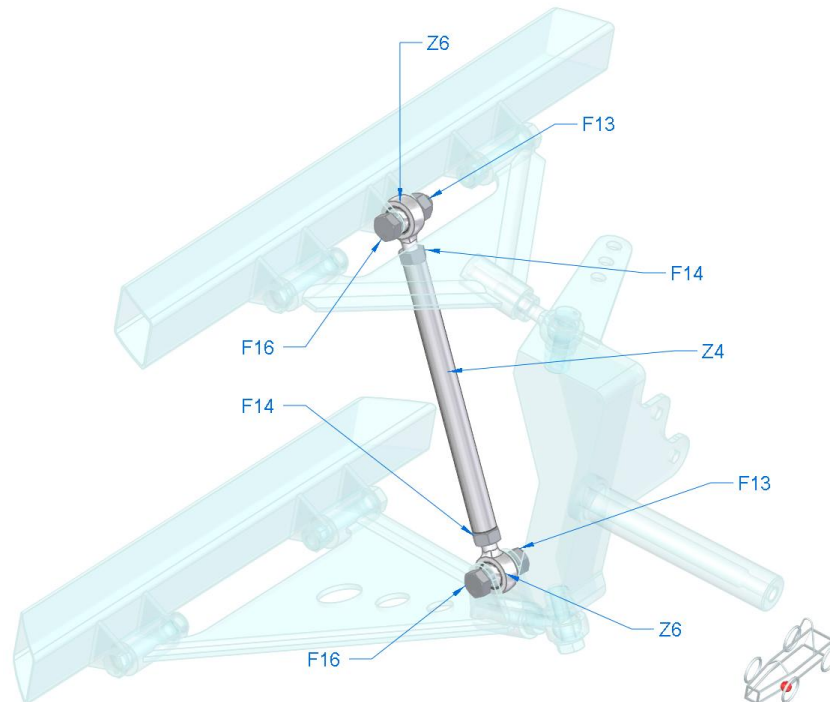


Figure 4.4.1.6
Torsion Rod - Left (Assembled)

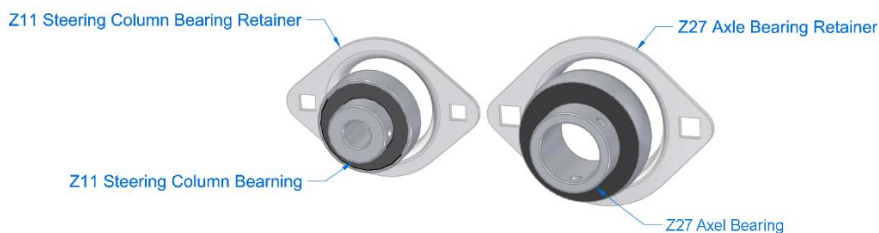
4.4.2 Steering Column Assembly

Table 4.4.2 Steering Column, Horn, Starter Parts

Part Number	Quantity	Description
Z11	2 sets	Each Bearing Assembly consists of: 2 Bearing Retainers (4 total) 1 Bearing (2 total) 2 Bearing Set Screws (4 total)
F6	4	M6 Washer
F7	4	M6 Nyloc Nut
F8	2	M6 x 12mm Socket Head Screw
F9	4	M6 x 20mm Cap Screw
F14	1	M8 Nut
F33	2	M6 x 35mm Socket Head Screw
F57	2	M8 x 16mm Set Screw
F59	1	M8 x 25mm Socket Head Screw
Z8	1	Steering Wheel
Z9	1	Steering Column
Z10	1	Steering Wheel Hub
Z11	2	Set Screw from the Z11 Steering Wheel Bearing assembly

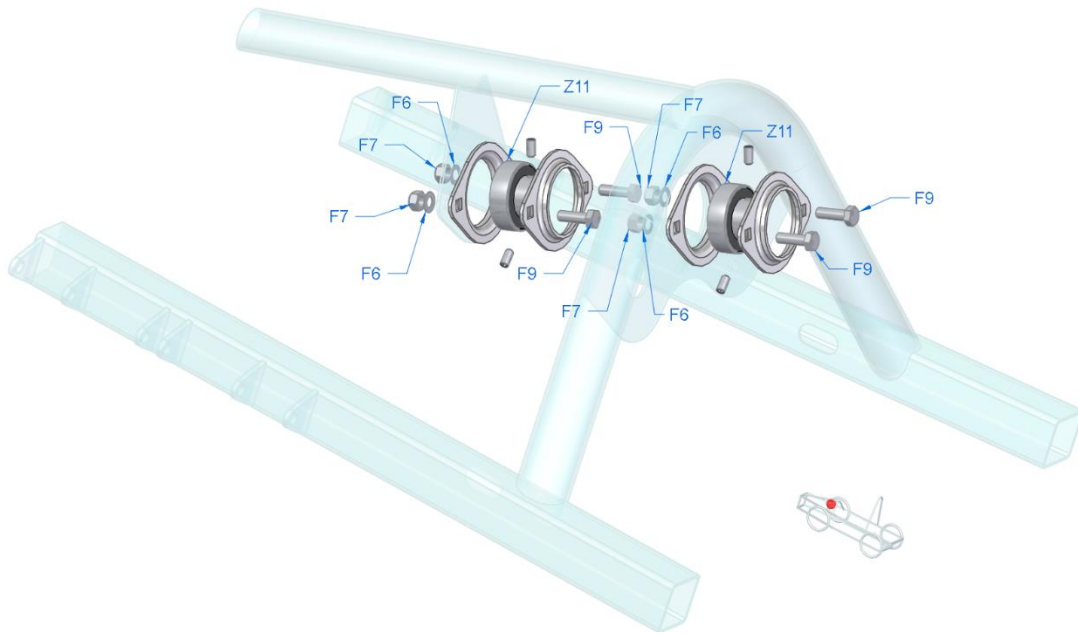
Procedure

1. Identify the Steering Column bearings using Figure 4.4.2.1. The part Z11 is for the Steering Column and Z27 is used for the rear axle in Unit 5: Drive Assembly.

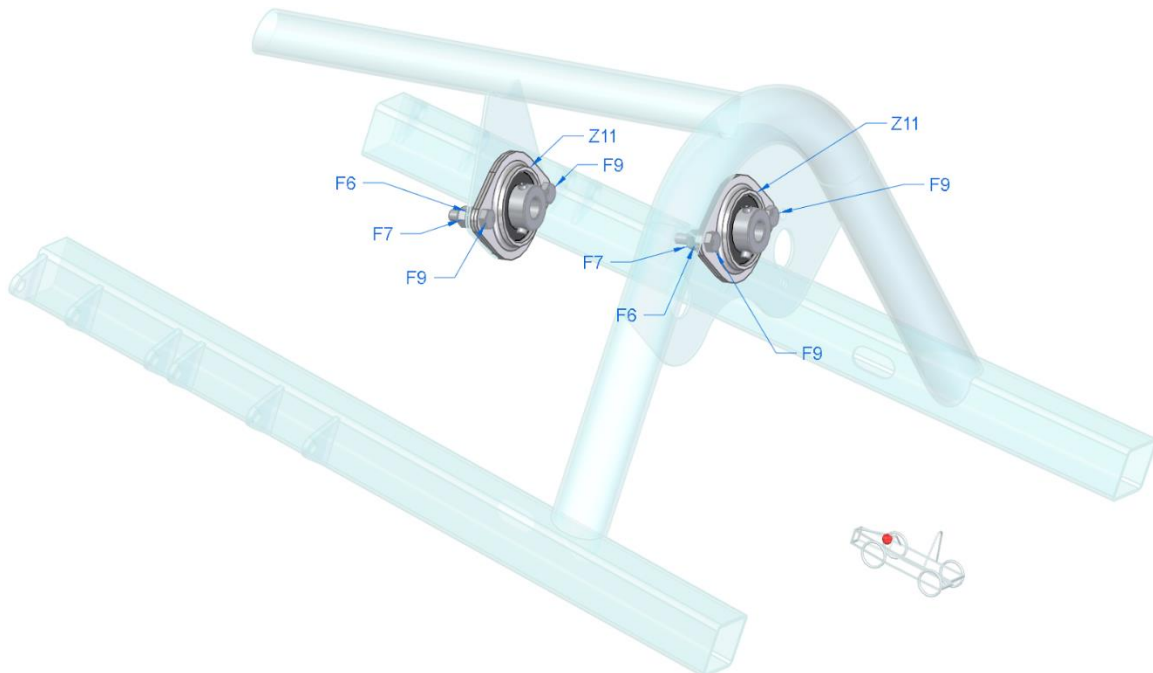


**Figure 4.4.2.1
Identifying Steering Column Bearing**

2. Install the Steering column bearings using the diagrams in Figure 4.4.2.2 and 4.4.2.3. Do not tighten any set screws until Z9, the steering column, is in its proper position.



**Figure 4.4.2.2
Steering Column Bearing Installation (Unassembled)**



**Figure 4.4.2.3
Steering Column Bearing Installation (Assembled)**

3. Install the Steering Column, Steering Wheel Hub and Steering Wheel as illustrated in Figure 4.4.2.4 and 4.4.2.5. Make sure the set screws, Z57, are installed properly into Z10 with the allen screw head to the outside. After getting them "finger tight", tighten them down with an allen wrench. Note that the diagram shows the Z11 set screws from the steering bearings which were installed in step 2; these may be tightened down onto Z9 as well.

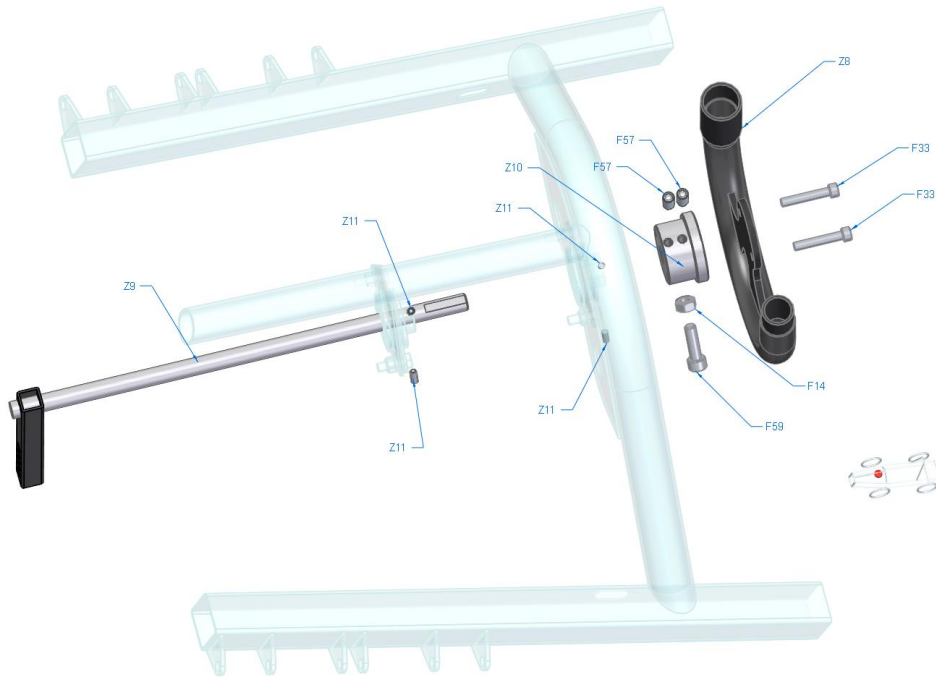


Figure 4.4.2.4
Steering Column Installation (Unassembled)

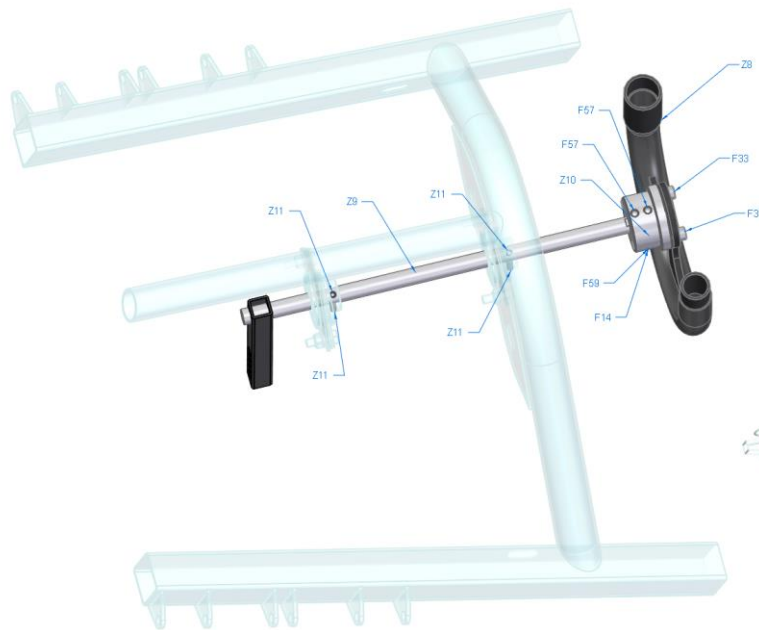


Figure 4.4.2.5

Steering Column Installation (Assembled)

4.4.3 Installing Steering Linkage Assembly

Table 4.4.3 Steering Linkage Assembly Parts

Part Number	Quantity	Description
Z12	4	Tie Rod Ends (Female)
Z13	1	Steering Connecting Rod. This rod must be cut to form two pieces.
F10	9	M8 Washer
F13	4	M8 Nyloc Nut
F14	4	M8 Nut
F16	3	M8 x 30mm
F17	1	M8 x 50mm

Procedure

1. Part Z13 comes in one piece. The students will need to measure and cut this into smaller pieces.
 - A. Before measuring the distance between axle brackets, make sure they are aligned properly both vertically (camber) and horizontally (toe). There will be room for adjustment even if the alignment is slightly off.
 - B. First, measure the longer distance making sure to account for the length needed to thread inside the tie rod end (Z12). Remember, measure twice and cut once.
 - C. Allow students to calculate what these links should be. For reference, the tie rod should be approximately 560mm and the drag link 265mm.
 - D. Use a hacksaw to cut the rod (reference the illustration below):
 - i. Mark the rod at the cut length using a permanent marker.
 - ii. Install two F14 M8 Nuts on each side of the cut mark (four total) this will help guide the cut as shown in the following illustration. Turn each pair to lock their location.
 - iii. Back the nuts off each side of the cut and lightly file the end to clean up any burrs caused by the cutting process. Use caution not to damage the threads.



iv. Once the longer rod is installed, measure for the smaller rod. This measurement needs to be taken from the steering column (Part Z9) to the driver's right side axle bracket. Use a hacksaw to cut the rod to length as defined above.

2. Figure 4.4.3.1 illustrates the steering linkage, identifying the tie rod and drag link.

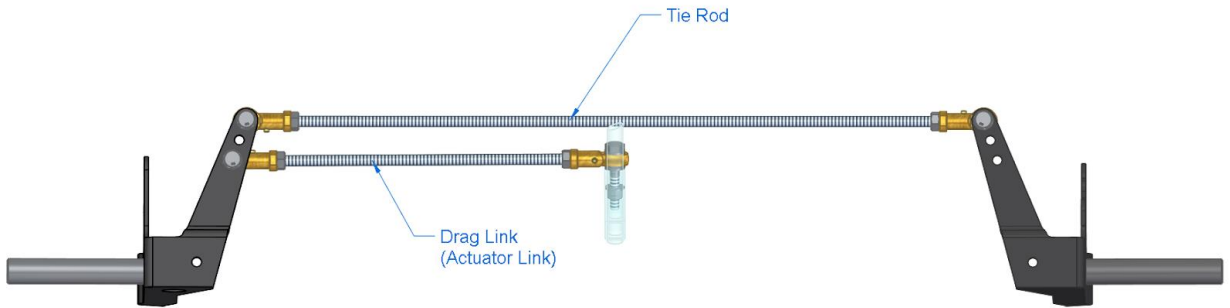
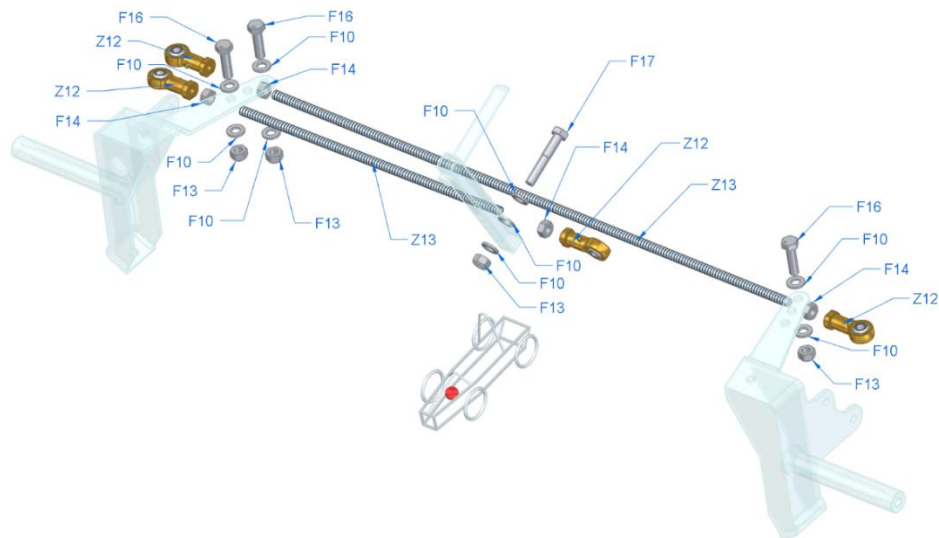
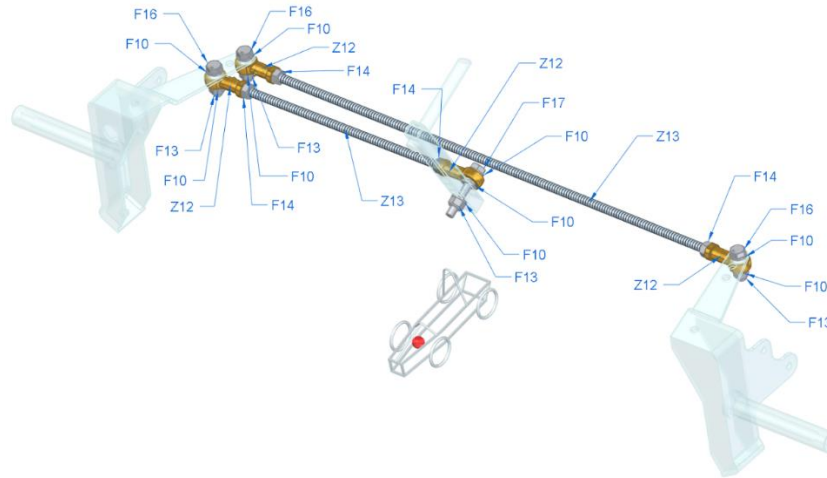


Figure 4.4.3.1
Tie Rod and Drag Link Illustration

3. Use Figure 4.4.3.2 and 4.4.3.3 to install the steering linkage.



**Figure 4.4.3.2
Steering Linkage Installation (Unassembled)**



**Figure 4.4.3.3
Steering Linkage Installation (Assembled)**

4.4.4 Tire Assembly

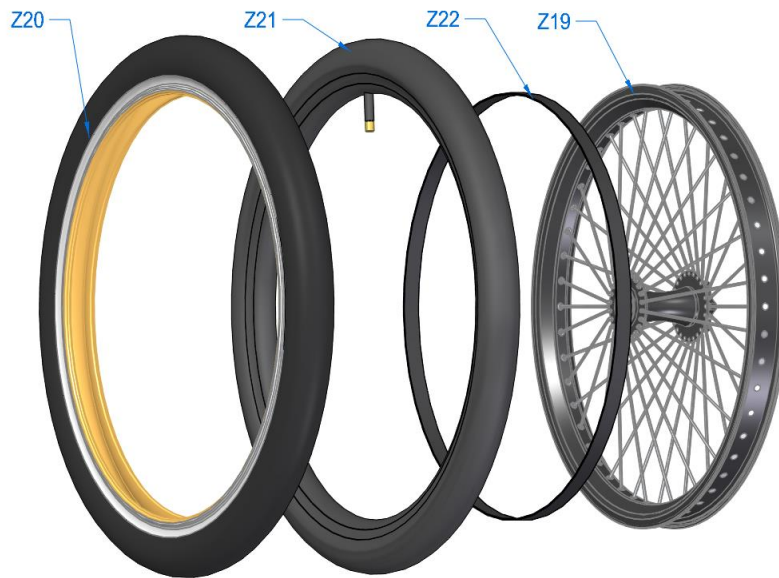
This section details the assembly of the tires. This unit can be done when timing is convenient or in parallel with other activities. The tires do not need to be placed on the stub axles until brake installation in section 4.4.5. The rear tires will not be installed until the entire drive unit structure is installed. See the end of Unit 5: Drive Assembly.

Table 4.4.4 Wheel and Brake parts

Part Number	Quantity	Description
Z19	4	Wheel
Z20	4	Tire
Z21	4	Inner Tube
Z22	4	Rim Tape
Z15	2	Brake Disc
	12	M5 x 12 mm brake disc screws
	4	Wheel Spacers (2 inner and 2 outer)
F19	2	M10 Lock washer (spring washer)
F20	2	M10 Nyloc Nut
F22	2	M10 x 40mm Socket Head screw

Procedure

1. Assemble the 4 tires:
 - a. Put Z22 around Z19.
 - b. Put Z21 inside Z20 and then install around Z19.
 - c. It may help to add a small amount of air (2 pumps) inside Z19 so that folds do not occur. Tire levers can be useful in getting the edge of the tire into the lip of the rim.
 - d. The two rear tires will be installed later in Unit 5: Drive Assembly.



2. Attach the brake discs to the front tires as shown in Figure 4.4.4.1; make sure the arrow on the disc is pointing to the front of the car. Pay close attention and note the difference between the inside and outside of the wheel as shown in the illustration below:

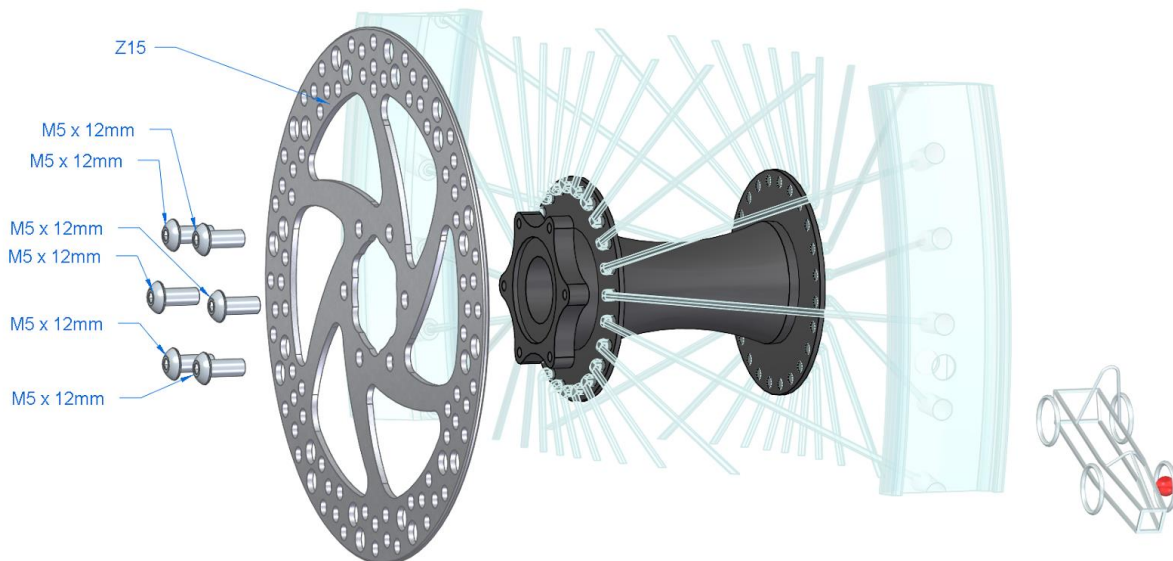


Figure 4.4.4.1
Attaching the Brake Disc to the Front Hub

3. Place the front wheels onto the front axles, noting the difference in the inner and outer wheel spacers as defined in Figure 4.4.4.2. The text on the side differentiates the inner and outer spacer. This process is illustrated in Figure 4.4.4.3 for the left side. Use the order for the right.

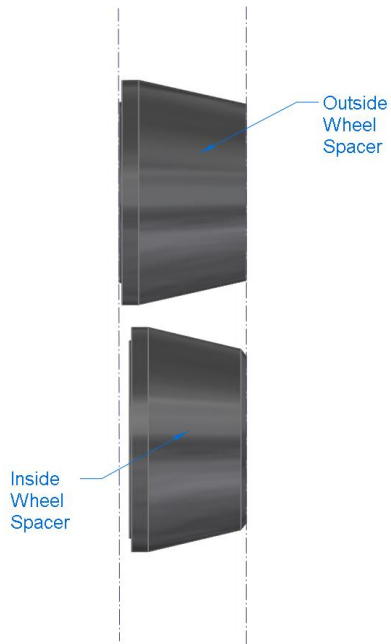
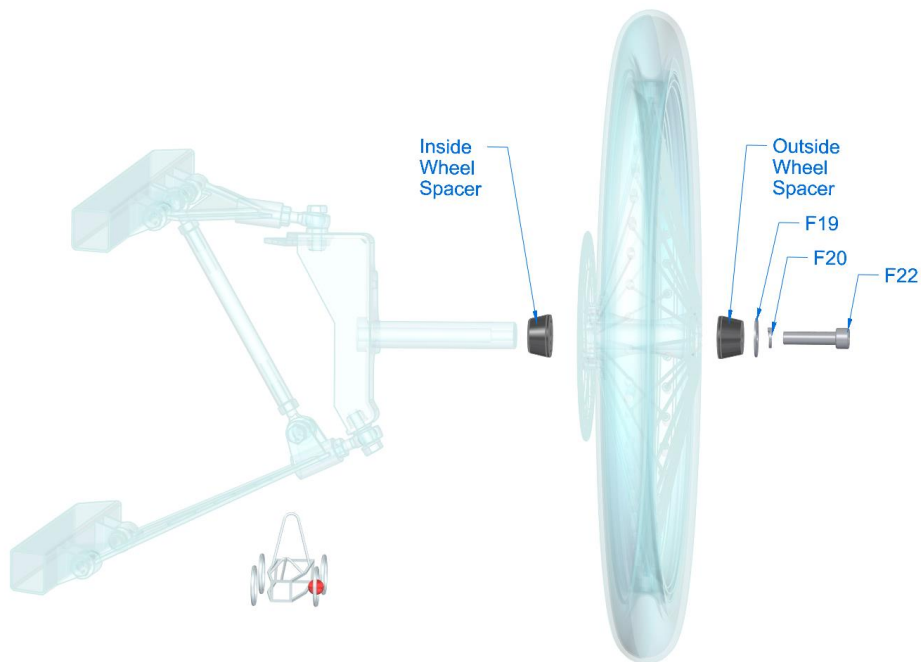


Figure 4.4.4.2
Identifying Wheel Spacers



**Figure 4.4.4.3
Left Front Wheel Installation**

4. Pump the tires to the desired PSI. The manufacturer's suggested pressure can be found on the side of the tires.

4.4.5 Installing Brake Assembly

Table 4.4.5 Brake Assembly Parts

Part Number	Quantity	Description
Z14	2	Brake Caliper
Z16	2	Brake Cable
Z18	1	Brake Lever
Z34	1	Brake Light microswitch
Z52	1	Brake Light Switch Bracket
F1	2	M3 x 20mm Slot head screw
F2	2	M3 Nyloc nut
F6	4	M6 Washer
F8	4	M5 x 12mm Socket Head Screw

Procedure

1. Insert the brake cable ends into the Brake lever and shown in Figure 4.4.5.1.

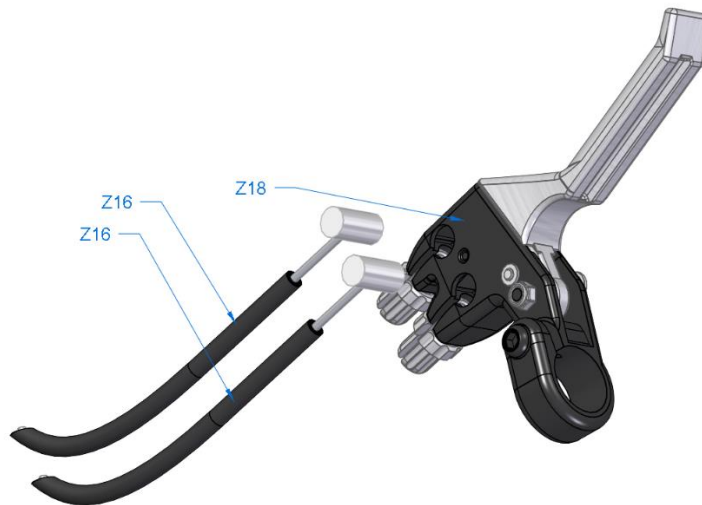


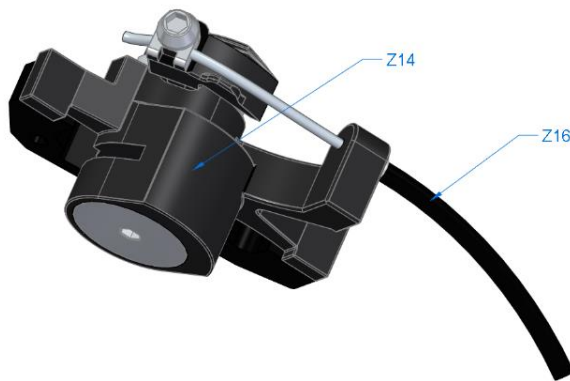
Figure 4.4.5.1
Installing Brake Cable to Brake Handle (Unassembled)

2. Install the brake lever onto the Steering wheel as shown in Figure 4.4.5.2. Use a screwdriver to open the clamp enough to slide it easily onto the steering wheel.



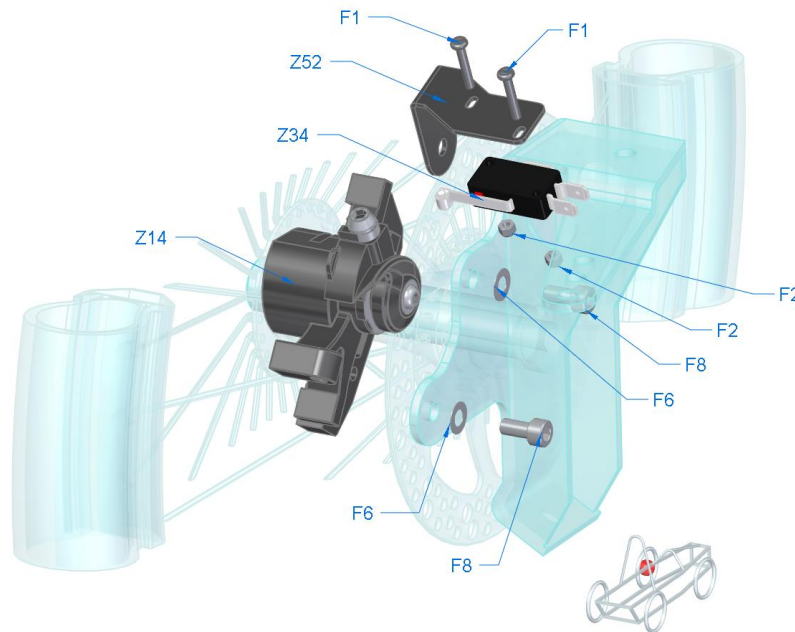
Figure 4.4.5.2
Brake Handle Installation

3. Insert the brake cable into the caliper as shown in Figure 4.4.5.3. Consider the following:
 - a. The best way to instruct students about the installation of the brake cables is to use online videos that provide a visual step-by-step view. Search video sharing websites using the key phrase “installing bicycle brake cables”.
 - b. It will be necessary to cut the cable to a desired length using a brake cable cutting tool. Be sure to wear eye protection.
 - c. The path taken from the brake lever to the brake caliper is a team design decision. Consider the organization of all wires and cables to ensure ease of access into your car and for repairs.

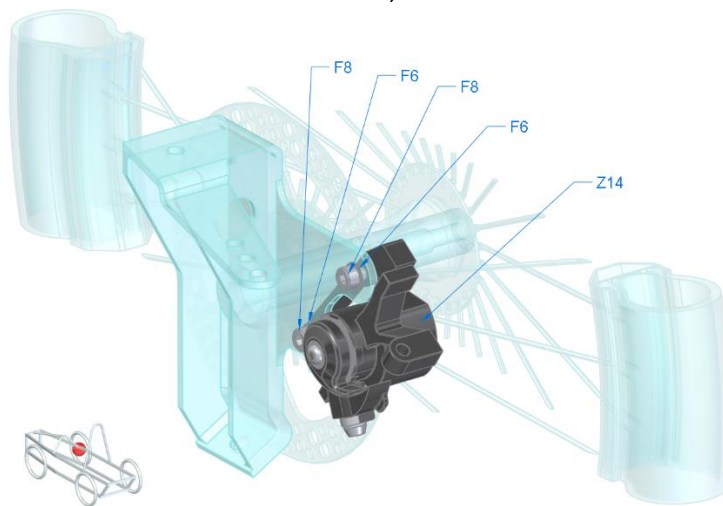


**Figure 4.4.5.3
Brake Cable to Brake Caliper Installation (Assembled)**

4. The brake caliper is now applied to the front wheels as seen for the left side in Figure 4.4.5.4. Note the image for the left side also includes the microswitch – which is installed only on the left side. Use mirrored order for the right side noting that the caliper will need to be in an upside position compared to the left - See Figure 4.4.5.5.
5. Install the microswitch and its bracket on the left brake as seen in Figure 4.4.5.4 and shown complete for the right in Figure 4.4.5.5.



**Figure 4.4.5.4
Left Front Brake Caliper, Microswitch Bracket, and Microswitch Installation**
(This image is unique to the left side of the car. The right side will not have a microswitch installed.)



**Figure 4.4.5.5
Right Front Brake Caliper (Assembled)**

4.4.6 Tuning Your Car (Post Build)

Adjusting Camber

- Refer to GreenpowerUSA.net for videos to help explain this concept.
- Using a ruler or yardstick, find the centerline of the front tires. Measure the distance between the tops of the tires as well as the bottom of the tires. These two measurements should be the same.
- Adjustments can be made by tightening/loosening the rod ends attached at the top and/or bottom of the axle brackets.

Adjusting Toe

- Using a ruler or yardstick, find the centerline of the front tires. Measure the distance between the fronts of the tires as well as the backs of the tires. Equal measurements result in equal toe.
- The adjustment for this primarily falls to the steering rod. To make adjustments, rotate the steering rod to the desired position.
- Tighten down the nuts once you have the rod in place.
- Further tuning may be required as data is collected on the car.

4.5 Supporting Activities

Build Phase

Wheel and Axles Discoveries (RI6-8.4; RI9-10.4; W6-8.8;W9-10.8; CCRASL-W8;CCRASL-R4; PS8.8,9; 7G.6)

- Student groups will research examples of wheels and axles. Research should not be limited to cars. See: <http://www.mikids.com/SMachinesWheels.htm> an example of pencil sharpeners and fans. Students should rank and present their most unusual find to the class.
- Lesson plan websites such as BrainPop provide other activity resources that investigate wheel and axle pairs as simple machines. <http://www.brainpop.com/educators/community/bp-topic/wheel-and-axle/>
- Students research the different types of axles used on vehicles, using, but not limiting to the following search terms: fork axle, stub axle, dead axle, floating axle, drive axle... Student groups present their findings to the class.
- Students research the evolution of wheels throughout the ages and present a timeline. An example resource can be found at: <http://www.tiki-toki.com/timeline/entry/226621/The-Evolution-of-the-Wheel/#vars!panel=2255259!> Student groups present their findings to the class. Through class discussion, predict what may be next.
- In CAD software, such as Siemens' Solid Edge, model the axle then model the bearing and see if they fit using an assembly feature of the software.

Catch This (PS8.8, 7EE.4)

- Using a pipe or rod made from a smooth material, students will explore the properties of friction by introducing substances that reduce friction.
 - The teacher will drop the rod vertically into a bucket of sand (or other soft material for padding).
 - The student will grasp the rod with one hand to stop it. Mark the rod where the top of his or her hand is located.

- Apply some form of lubrication to the rod. For example:
 - Baby Oil
 - Sunscreen
 - Dish Soap
 - Students can make suggestions about additional materials
- Repeat the same procedure and mark the rod at the top of their hand.
 - Clean the rod so the different substances do not affect one another.
 - Combining substances could be an extension to this activity.
- Encourage discussion of outside factors that affect the results such as reaction time and the learning curve.
- This activity helps students understand how different surfaces effect friction.
- Another suggestion is having students wear different types of gloves.
- Make sure students are wearing closed-toed shoes while doing this activity.

I Need a Brake (RI6-8.4, PS8.8,10,11)

- Engineering websites such as <http://tryengineering.org/lesson-plans/give-me-brake> offer activities/lesson plans associated with bicycle brakes
- Have Students research various types of brakes used on vehicles. Use key search terms such as disc brake, drum brake, rim brake. Create a chart defining the similarities and differences in the way each functions.
- Bring in a bicycle with rim brakes. Have the students write an explanation, using correct terminology, about the way the brakes work. After spinning the tire and applying the brake, have the students explore heat associated with braking. Discuss forms of energy that exist while the bike is spinning versus when the brakes are holding the bike in place.

Newton's Three Laws of Motion (PS8.8,10,11)

- Use on-line engineering websites and educational videos to present information on Newton's three laws: <http://teachertech.rice.edu/Participants/louviere/Newton/law1.html> http://www.physics4kids.com/files/motion_laws.html Students collaboratively list three real-world examples of each of the three laws.

Ackermann Steering Geometry (7G.2,5; 8G.5; PS8.9; CCASL-R3,4,5)

- Students will research Ackermann Steering Geometry by watching online instructional videos.
- Students will measure the angles of and draw an angle representation of the steering geometry of the F24. Use masking tape to mark out the projection of the existing angles onto the floor to aid in measuring the angles.

Steering Styles (7G.2,5; 8G.5, PS8.9; CCASL-R3,R4)

- Students will research types of steering designs: Rack-and-Pinion, Pivot Arm, Dual Levers, Tiller and Joy Stick. Students identify the type found in the Greenpower car. Compare and contrast the styles and the amount of control each provides.

Post Build

Tires are Not All the Same (6EE.9; 7EE.4; 7G.4; 8SP.3; A-CED2; F-IF4; AC-5)

- Students should be able to identify the tire size, composition, and recommended tire pressure of the car's tires.
- Tire pressure plays a part in the car's performance. Using procedures defined in Unit 9 Driving, Data Collection and Analysis, students will perform data collection runs that involve tire pressure adjustments to determine its effect on performance.
- Environmental temperature affects air pressure. Students should conduct an experiment to see how air pressure is affected by varying temperatures. An indoor control should be established, tire pressure measured, and recorded. The tire should then be moved outside, readings should be taken at intervals as the outdoor temperature changes and graphed. Create equations to describe the relationship that emerges between temperature and tire pressure.

The Toe and Camber Sweet Spot (7G.2,5; 8G.5, PS8.9; CCRASL-R3,R4)

- GreenpowerUSA.net has videos that support this lesson.
- Students will research and find recommendations on adjusting away from equal toe and neutral camber and how it affects performance.
- Using procedures defined in Unit 9 Driving, Data Collection and Analysis, students will compare data from trial runs. Analyzing data may result in adjusting the toe in order to find the correct toe setting. Repeat trials adjusting the camber to fine tune that setting, as well.

Descriptive Writing (W6-8.2,4,5,9,10; W9-10.2,4,5,9,10; CCRASL.W2,4,5,9,10)

- Descriptive writing is a necessary tool for engineers. Have students pick one component application and define in steps how it is constructed/applied to the car. This can be done in bulleted steps. Remind students that correct writing dictates that these be parallel in structure. Clarity is important and should ensure that someone can follow the directions to attain the desired result.

4.6 Teacher Recommendations

- This unit is a good place to ask an expert for help. Bike enthusiasts can be helpful with the brakes and the tires.
- Since the bolts are not tightened completely until everything is positioned correctly, you may want to adopt a policy of marking the bolt head with a dot of paint when it has been fully tightened.
- While driving the car, the team may want to consider rotating the tires or driving in the opposite direction to reduce uneven tread wear.

The logo for Unit 5: Drive Assembly features a stylized blue car wheel and tire on the left, with a blue swoosh that extends to the right, ending in a blue oval shape. The text "Unit 5: Drive" is positioned above the wheel, and "Assembly" is positioned below it, both in a black sans-serif font.

Unit 5: Drive Assembly

5.1 Reference Standards

Note that these standards will be applied throughout this unit. For the complete standard, please see Appendix A.

Language Standards

- L6-8.4, L9-10.4 (Determine the meaning of unknown and multiple-meaning words or phrases)
- L6-8.6, L9-10.6 (Using terms correctly in context)

Writing Standards

- W6-8.1, W9-10.1, CCRA-SL-W1 (Write arguments to support claims)
- W6-8.2, W9-10.2, CCRA-SL-W2 (Write informative or explanatory text to convey concepts)
- W6-8.6, W9-10.6, CCRA-SL-W6 (Utilize technology to produce and publish writing)
- W6-8.8, W9-10.8, CCRA-SL-W8 (Gather relevant information from print and digital resources)
- W6-8.9, W9-10.9, CCRA-SL-W9 (Draw evidence to support writing)

Speaking and Listening Standards

- SL6-8.1, SL9-10.1 (Engage in collaborative discussions)
- SL6-8.3, SL9-10.3 (Evaluate reasoning and relevance of claims)
- SL6-8.4, SL9-10.4 (Present claims in a coherent manner)
- SL6-8.5, SL9-10.5 (Integrate multimedia to clarify information)

Reading Standards

- RI6-8.4, RI9-10.4, CCRA-SL-R4 (Determine the meaning of words used in text)
- RI6-8.7, RI9-10.7 (Evaluate the advantages of using different presentation mediums)
- CCRA-SL-R5 (Analyze relationship among concepts/key terms presented in text)
- CCRA-SL-R7 (Translate visual data into text or words to visual representation)

Math Standards

- 6RP.1 (Understanding and using ratios)
- 6RP.2 (Understand and use unit rate appropriately in the context of a ratio)
- 6RP.3 (Use ratio and rate reasoning to solve real-world problems)
- 6NS.1 (Fluently divide multi-digit numbers)
- 6EE.9 (Use variables to represent two quantities that change in relationship to one another)
- 6SP.4 (Display numerical data plots)
- 6SP.5 (Summarize numerical data in relation to their context)
- 7RP.1 (Compute unit rates associated with ratios of fractions)
- 7RP.2 (Recognize and represent proportional relationships between quantities)

- 7RP.3 (Use proportional relationships to solve multistep problems)
- 7NS.2 (Multiply and divide rational numbers)
- 7NS.3 (Solve real-world problems involving the four operations)
- 7EE.4 (Use variables to represent quantities in a real-world problem)
- 7G.4 (Area and Circumference of a circle)
- 8EE.5 (Graph proportional relationships, interpreting the unit rate as slope)
- 8SP.1 (Construct and interpret scatter plots)
- A-CED1 (Create equations and inequalities in one variable to solve problem)
- A-CED2 (Create equations in 2 or more variables to represent relationships)

Science Standards

Physical Science (8th)

- PS8.1 (Identify steps within the scientific process)
- PS8.9 (Mechanical advantages of simple machines)
- PS8.11 (Effects on electric forces)

Physical Science (9-12)

- PS9-12.12 (Design a device to convert from one form of energy to another)

Technology Education Standards (Alabama)

- TE6-8.5 (Use basic features of productivity software)
- TE6-8.9 (Practice responsible and legal use of technology systems and digital content)
- TE6-8.11, TE9-12.12 (Use digital tools to synthesize information)
- TE9-12.5 (Use advanced features of spreadsheets)
- TE9-12.6 (Multimedia presentations)
- TE9-12.9 (Ethical use of digital content)
- TE9-12.11 (Critique digital content for accuracy, bias, currency, relevance)

5.2 General Overview

In this unit, students will concentrate on the drivetrain and the electrical motor system that provide power to the car. The drivetrain takes the motor's electrical power and translates it to mechanical energy to move the wheels of the car. These components will be installed into the rear of the car in the build phase of this unit. The chain tension affects the overall performance of the car. In the post-build phase, students investigate the cause and effect on the motor and battery performance for different chain tensions.

Objectives

In this unit, students will:

- Assemble the rear wheels and drivetrain.
- Understand the operation of various types of drive mechanisms.
- Mathematically explore the effects of various gear ratio combinations.
- Explain the relationship between chain tension and performance.
- Understand the mechanical advantage of simple machines connected to one another.

Key Vocabulary

- Bearings
- Drive wheel
- Drivetrain
- Emery cloth
- Gear Ratio

- Roll pin
- Roller Chain
- Sprocket

Pacing

Allow approximately 2 weeks to complete the build activities in this unit.

5.3 Materials and Tools

Table 5.3 Drive Assembly Materials and Tools

Tool	Description
Safety Glasses	Always wear safety glasses when working around the car.
Hex Wrench	To assemble the Socket Head Screws
Wrenches/Sockets	To assemble rear wheels to axle
Soft Mallet	To install Roll Pin (F23) through left rear Wheel Hub and axle
Emery Cloth	To polish the axles for smooth installation of the wheels as needed

5.4 Unit Procedure

5.4.1 Installing the Rear Drive Wheel Assembly

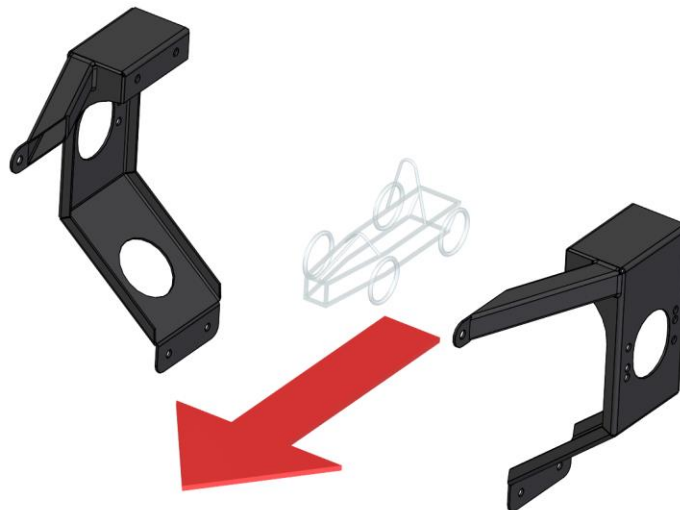
Table 5.4.1 Rear Drive Wheel Assembly Parts

Part Number	Quantity	Description
F10	28	M8 Washer
F13	14	M8 Nyloc Nut
F15	4	F15 M8 x 20mm Screw
F17	10	M8 x 50mm Cap Screw
F23	1	Roll Pin
F3	6	M5 Spring Washer
F5	6	M5 x 20mm Socket Head Screw

Z19-22	2	Assembled rear wheels from Unit 4
Z25	1	Axle Sprocket
Z26	2	Sprocket/Wheel Hub
Z27	2 sets	Axle Bearing
Z28	1	Axle
Z54	4	Load Spread Plate
Z60	1	Electronics Mounting Plate
Z7	2	Rear Axle Bracket (right)

Procedure

1. Retrieve the rear tires assembled in Unit 4, section 4.4.4.
2. Install the Rear Axle Brackets (Z7) referring to Figures 5.4.1.2 through 5.4.1.5 (Left and right views). Note the orientation in the Figure 5.4.1.1 below. Also note that Z60, the electronics mounting plate is installed here, only on the right side, inside the frame. This plate appears here because its supporting bolts coincide with those of the axle bracket. This plate will be referenced again in Unit 6.



**Figure 5.4.1.1
Rear Axle Bracket Orientation**

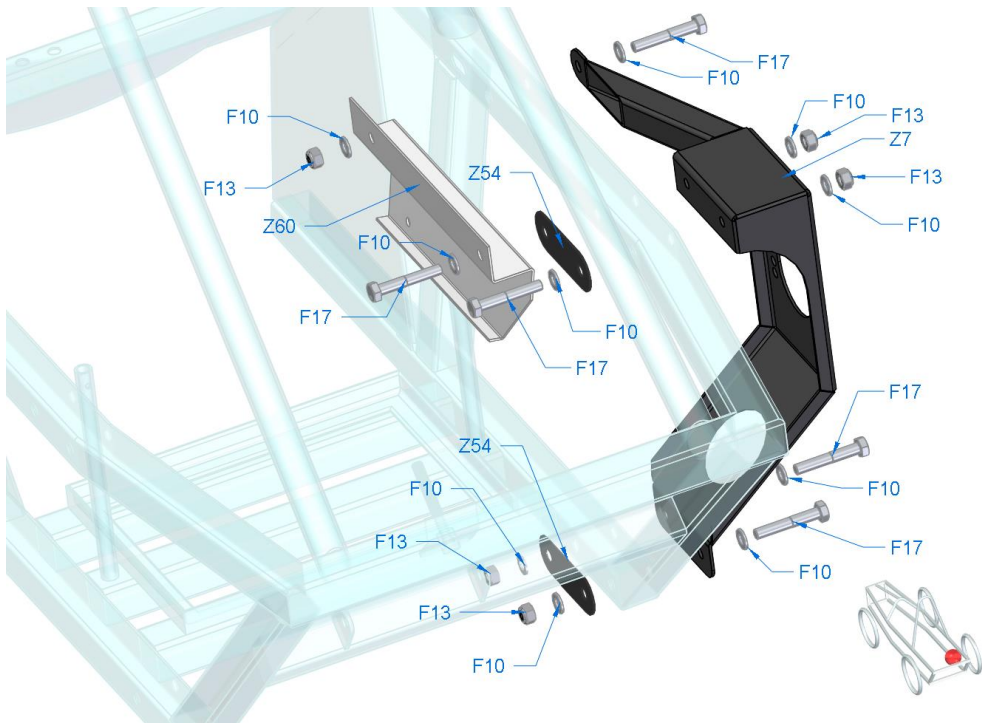


Figure 5.4.1.2
Right Rear Axle Bracket Installation (Unassembled)

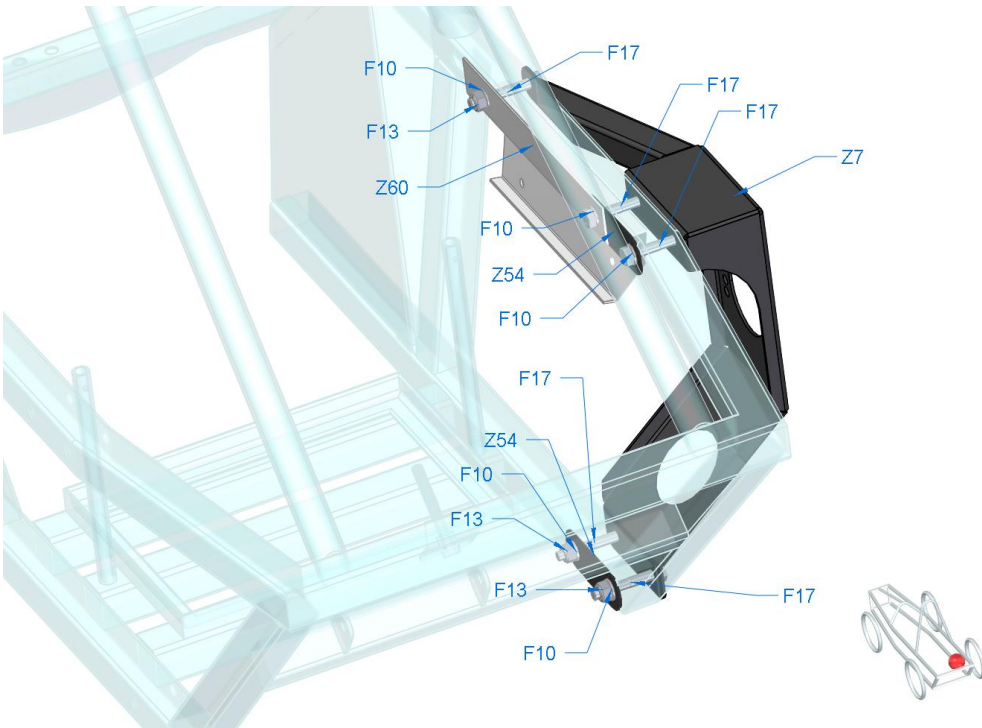


Figure 5.4.1.3
Right Rear Axle Bracket Installation (Assembled)

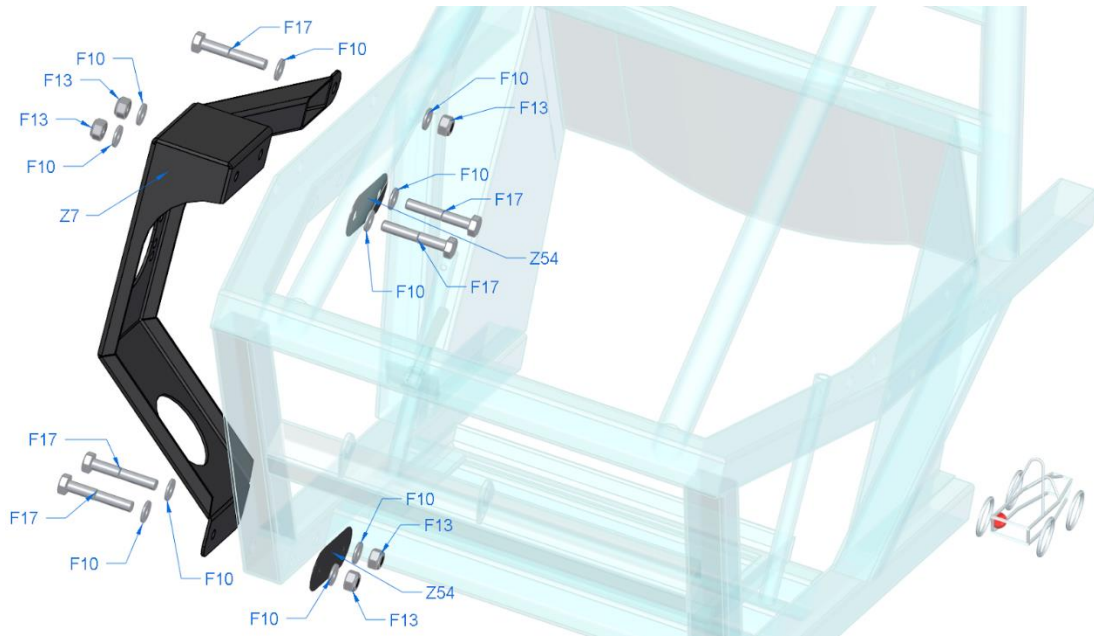


Figure 5.4.1.4
Left Rear Axle Bracket Installation (Unassembled)

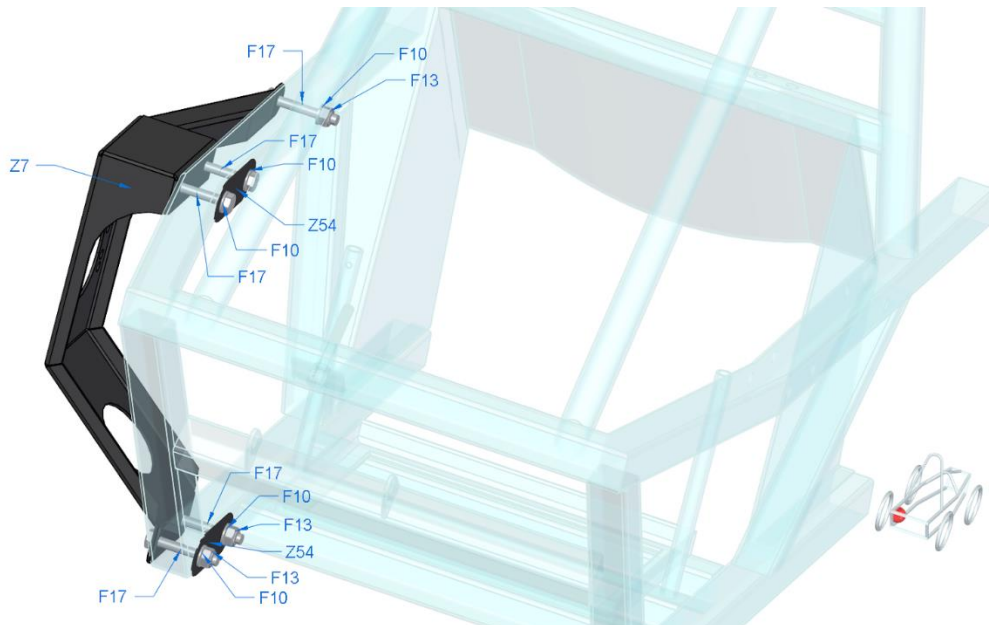


Figure 5.4.1.5
Left Rear Axle Bracket Installation (Assembled)

3. Attach the Axle Sprocket (Z25) to a Sprocket/Wheel Hub (Z26) as shown in Figure 5.4.1.6 and 5.4.1.7. Be sure to attach these two pieces using all six socket head screws (F5). Do not install the roll pin (F23) at this time. It is shown in the illustrations for reference and to assist in knowing where, along the axle, the sprocket is installed. This pin will be inserted in step 9 of section 5.4.2.

Note: Do not force or beat the Sprocket/Wheel Hub into place. Use an Emery cloth to smooth the surface of the axle, as needed, to get a proper fit.

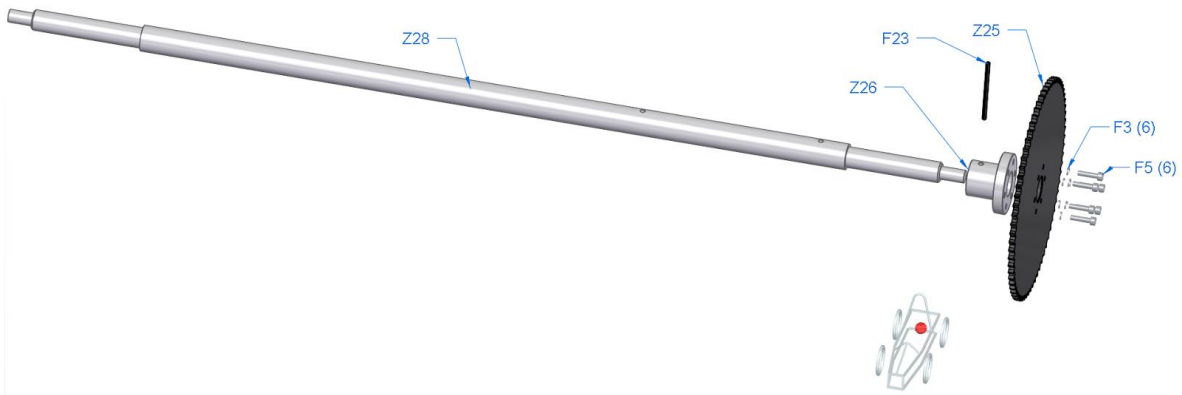


Figure 5.4.1.6
Rear Axle Assembly (Unassembled)

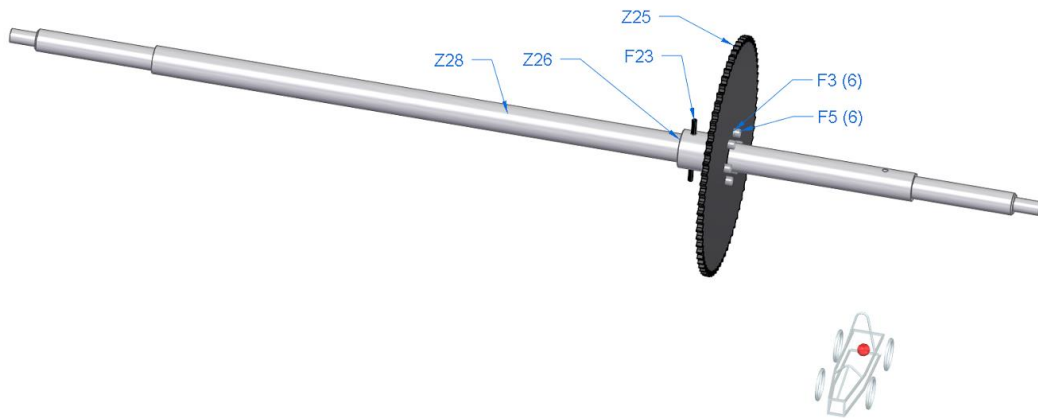


Figure 5.4.1.7
Rear Axle Assembly (Assembled)

4. Place the Rear Axle into the frame using the steps provided in Figures 5.4.1.8 and 5.4.1.9. Place the right end of the axle into its slot. Slide the axle to the right until the axle can drop down into the frame, then slide the axle to the left to place it in the left slot as well. Note: the bearings will be attached in the next step to support and position the axle.

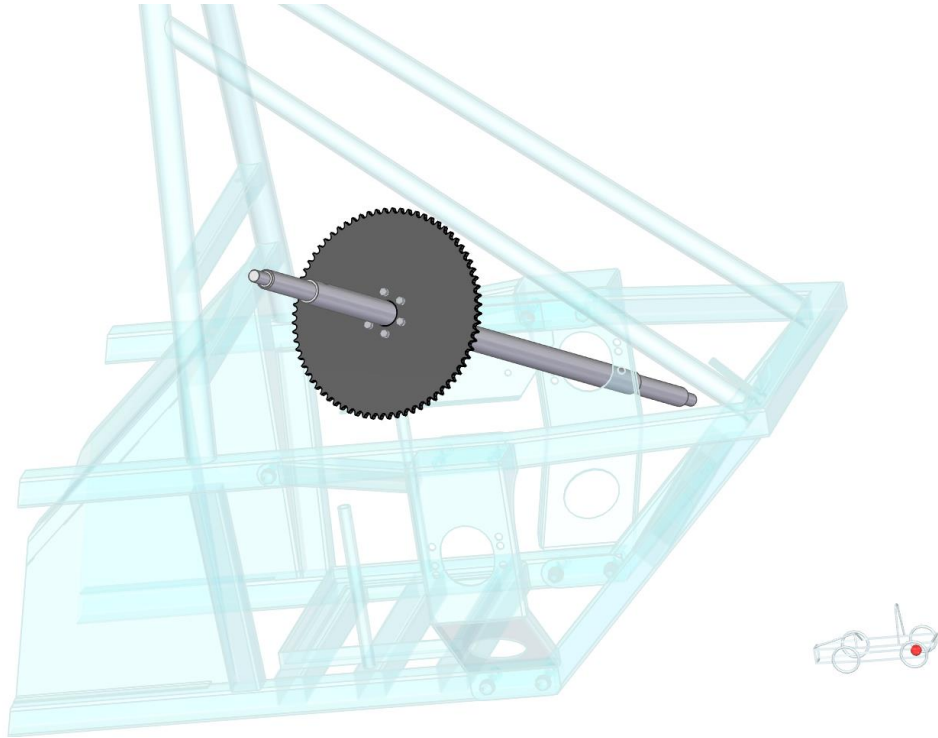


Figure 5.4.1.8
Rear Axle Installation Part 1

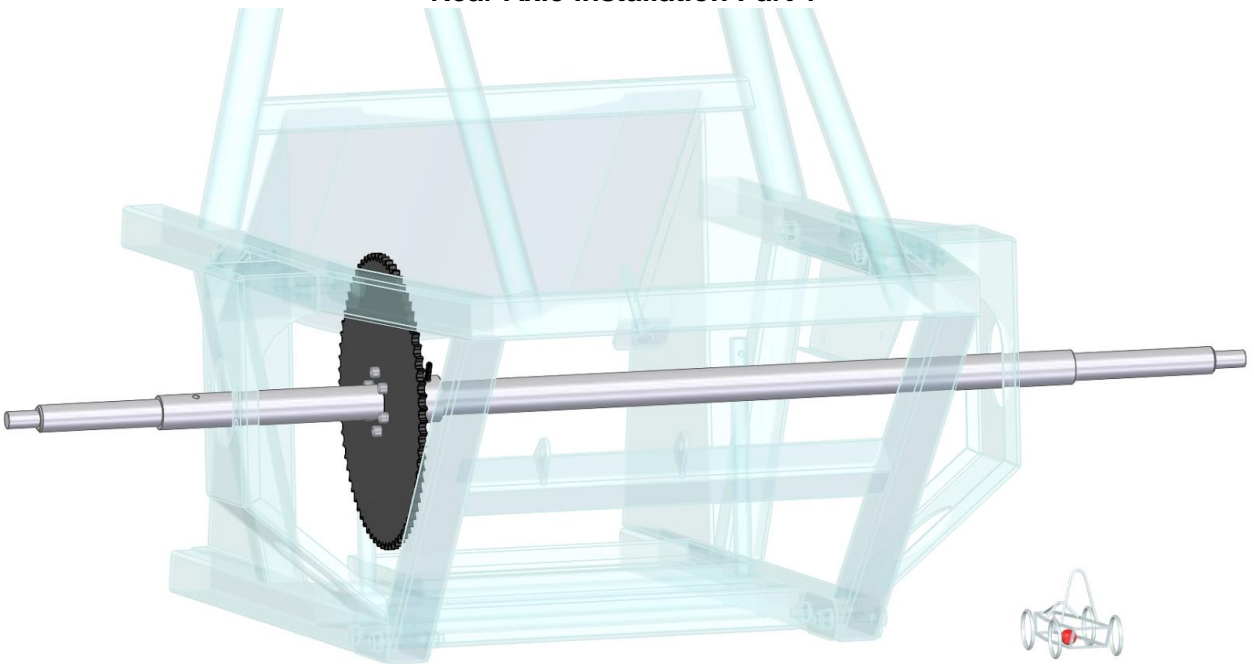


Figure 5.4.1.9
Rear Axle Installation Part 2

- Install the Axle Bearings (Z27) as shown in 5.4.1.11 and 12. Do not tighten the F15 bolts nor Z27's setscrews until you have the axle fully in place. There are three hole patterns on the axle bracket that can be used to install to the bearing as shown in Figure 5.4.1.10. Each pair of holes represents a different rear axle installation height. The C location raises the axle the most, providing the least ground clearance. The B location lowers the axle the most, providing the most ground clearance. By regulation, the ground clearance must not be less than 30mm. Identical hole patterns must be used on the left and right rear axle bearings to ensure a level installation. Note: If minor axle height adjustments need to be made, the hole pattern choice can be changed.

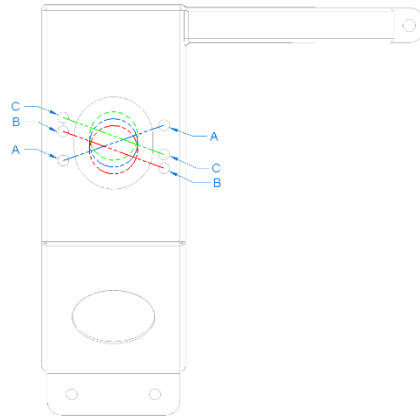


Figure 5.4.1.10
Rear Axle Bearing Mounting Plate Hole Patterns

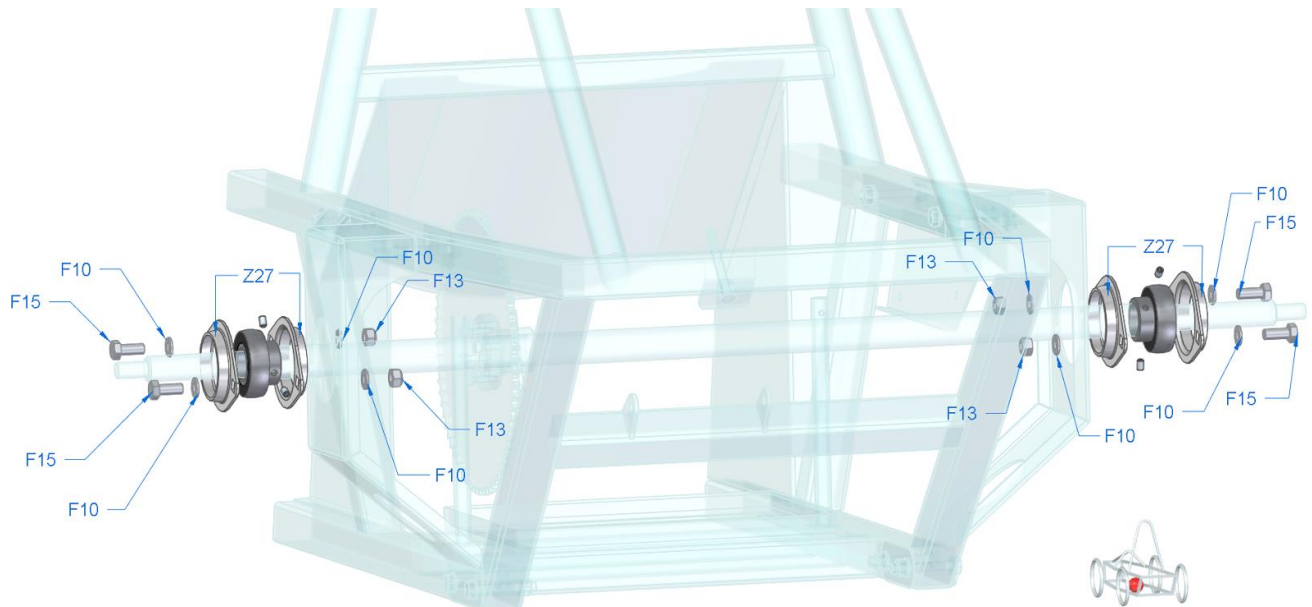


Figure 5.4.1.11
Rear Axle Bearing Assembly (Unassembled)

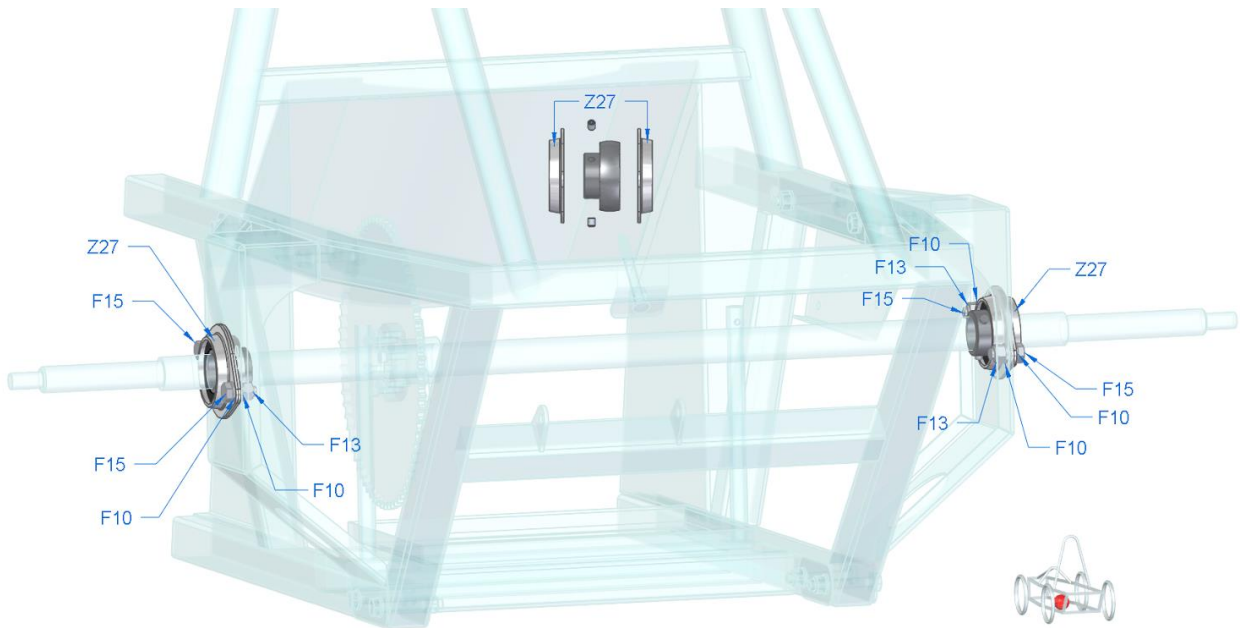


Figure 5.4.1.12
Rear Axle Bearing Assembly (Assembled)
 (Note: the Z27 part consists of 5 pieces as shown in the center of this illustration.)

5.4.2 Installing the Drive Motor and Chain Assembly

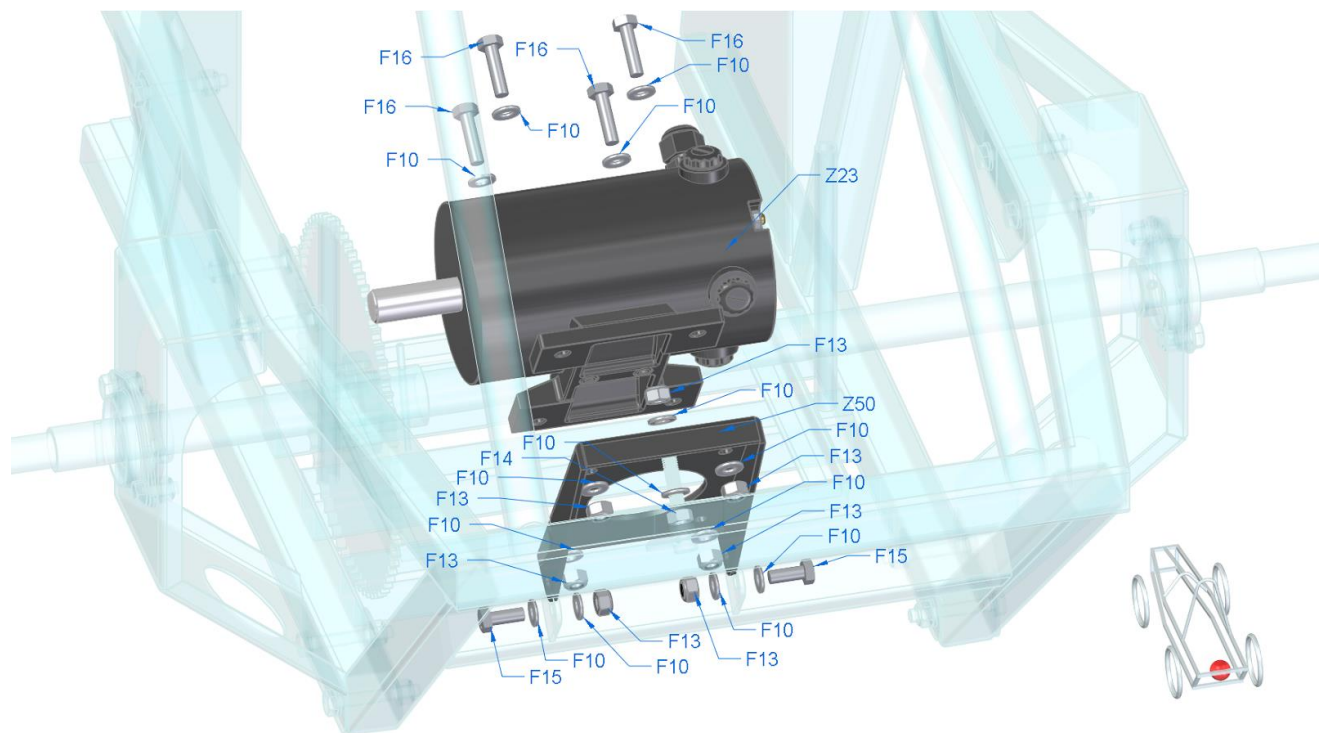
Table 5.4.2 Drive Motor and Chain Assembly Parts

Part Number	Quantity	Description
Z23	1	Motor
Z24	1	Motor Sprocket
Z26	1	Drive Wheel Coupling
Z29	1	Roller Chain
Z30	1	Chain Link (3 parts)
Z50	1	Chain Tensioner Bracket
F3	6	M5 Spring Washer
F5	6	M5 x 20mm Socket Head Screw
F10	14	M8 Washer
F13	7	M8 Nyloc Nut

F14	1	M8 Nut
F15	2	M8 x 20mm Cap Screw
F16	4	M8 x 30mm Cap Screw
F18	2	M10 Penny Washer
F20	2	F20 M10 Nyloc Nut
F23	1	Roll Pin
	3	Hub spacers

Procedure

1. Attach the motor (Z23) to the Chain Tensioner Bracket (Z50) with all four F16 bolts. These four bolts can be completely tightened. Reference Figure 5.4.2.1 and 5.4.2.2.
2. Attach this motor and mounting bracket assembly to the frame of the car with the 2 F15 bolts at the lower pivot point and the F14 at the upper center as shown in Figure 5.4.2.1. Do not overtighten part F15. The mount assembly should rotate to allow adjustments for proper chain tension. These F15s will be tightened further in step 7.



**Figure 5.4.2.1
Motor Mount (Unassembled)**

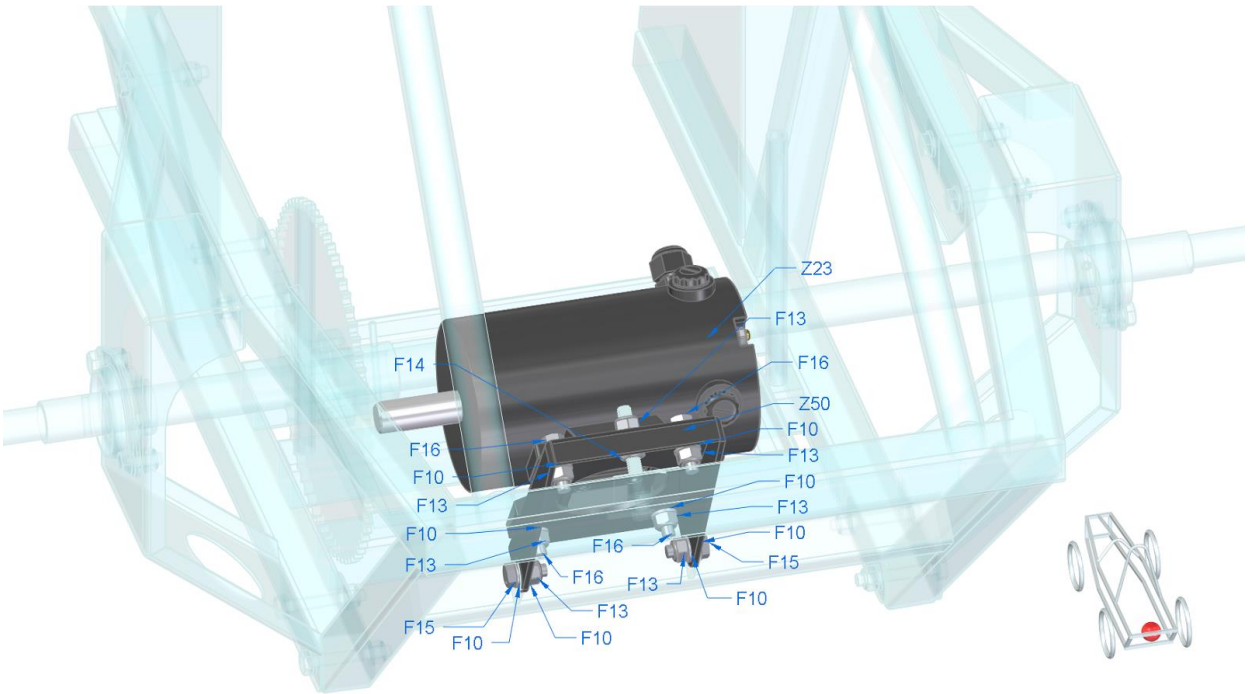


Figure 5.4.2.2
Motor Mount (Assembled)

3. Attach the Motor Sprocket (Z24) to the motor as shown in Figure 5.4.2.3 and 5.4.2.4. Pay attention to the flat part of the sprocket and motor shaft. Do not completely tighten the set screws at this time. These will be set in step 5b. To insure proper fit of the Motor Sprocket, it may be necessary to lightly polish the motor shaft with an Emery cloth.

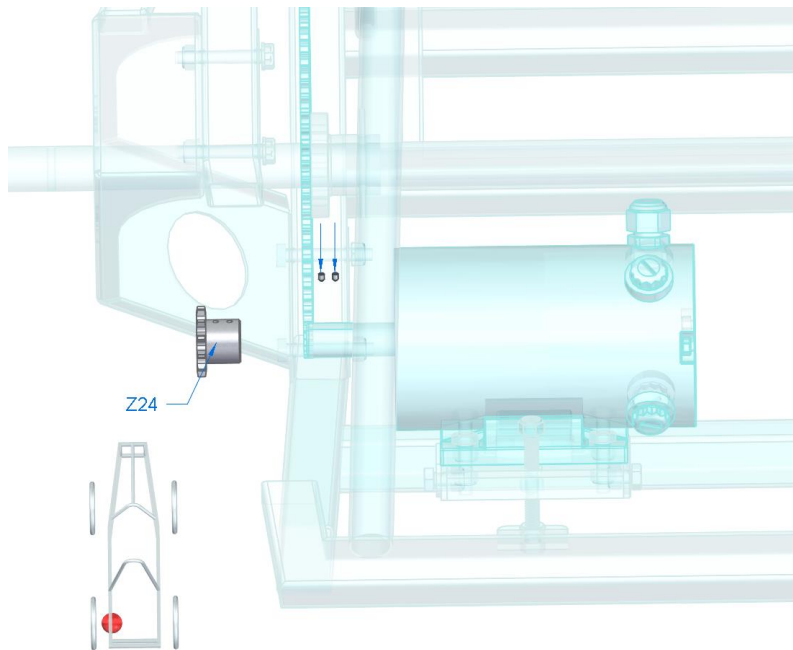
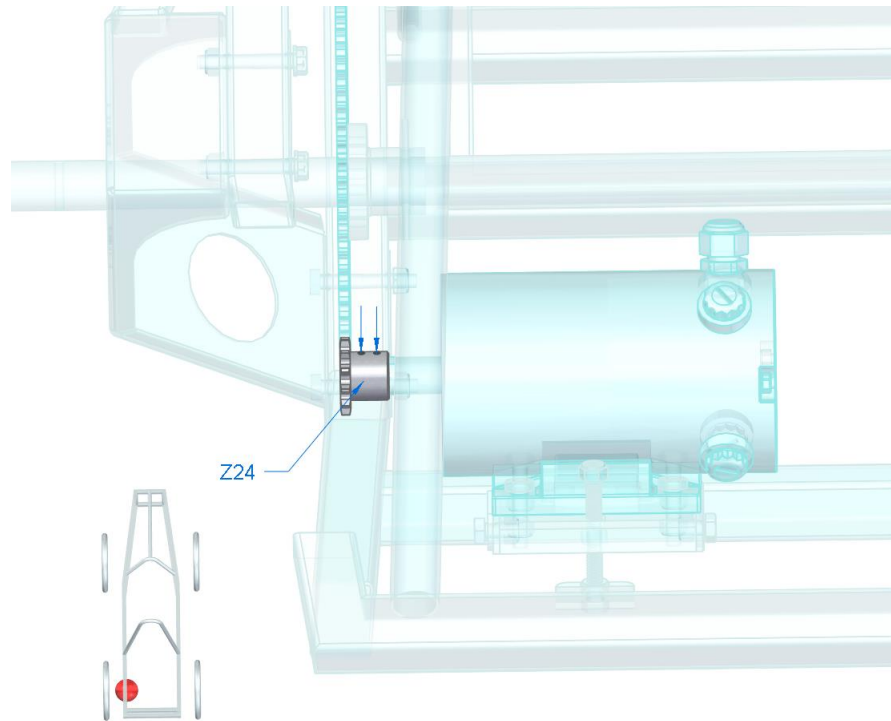


Figure 5.4.2.3
Motor Sprocket to Motor (Unassembled)



**Figure 5.4.2.4
Motor Sprocket to Motor (Assembled)**

4. Place the chain over the larger sprocket and the motor sprocket as shown in Figure 5.4.2.5 and 5.4.2.6. Use the Chain Link (Z30), sliding the c-clip on from the side, to connect both ends of the chain.
5. Align both sprockets so they are in the same geometric plane. In other words, the sprockets need to be in line with one another so that the chain functions properly.
 - a. To adjust the alignment of the sprockets, both the rear axle and the motor sprocket can be slid right or left until they are in proper alignment with one another.
 - b. Once aligned, tighten the set screws on the Motor Sprocket and both axle bearings (Z27). Tighten as much as possible.
6. At this point, adjust the tension of the chain by tightening/loosening F14 under the Chain Tensioner Bracket.
7. Once the desired tension is achieved, tighten down the F15s at the pivot points on the base of the Chain Tensioner Bracket. The F14 Locknut then needs to be tightened underneath the pivot plate.

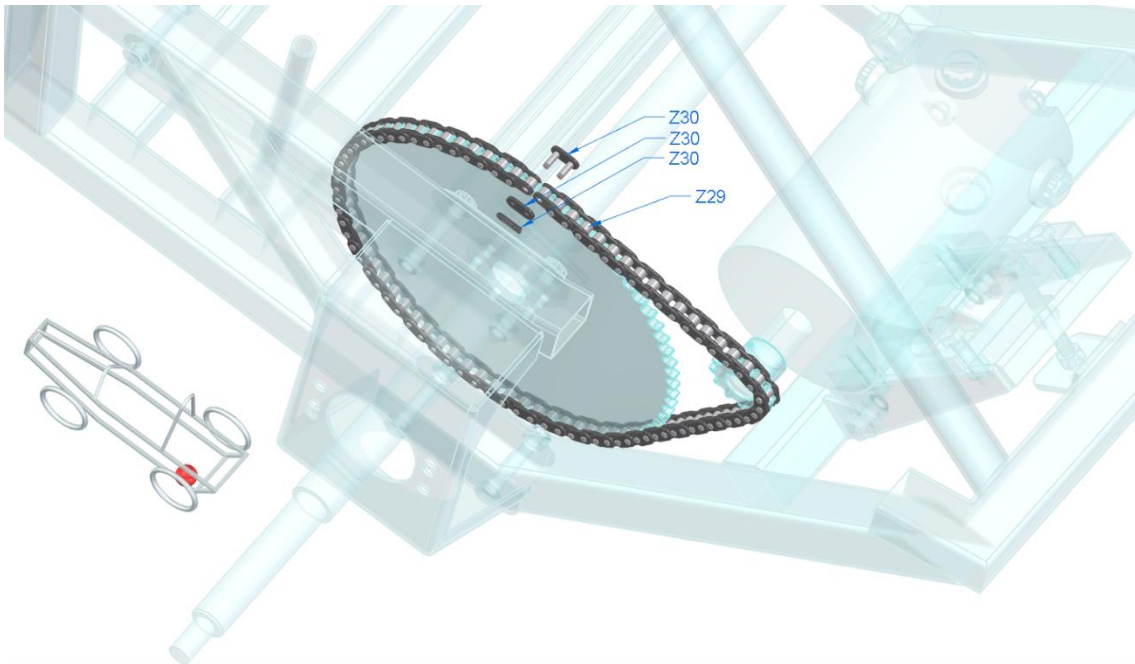


Figure 5.4.2.5
Chain Assembly and Installation (Unassembled)

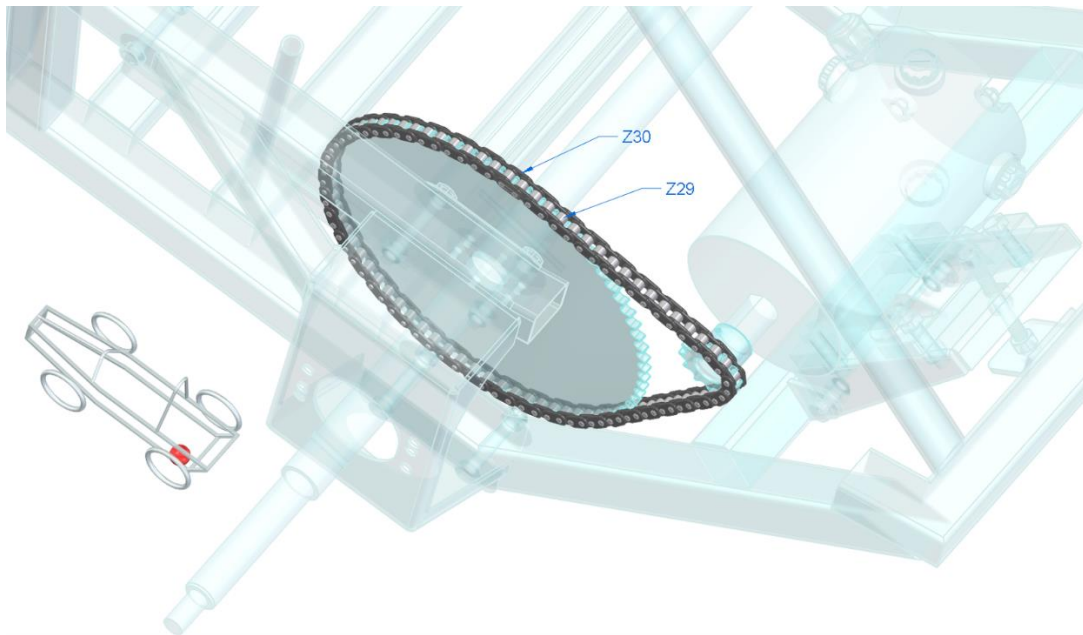


Figure 5.4.2.6
Chain Assembly and Installation (Assembled)

8. Prepare the left rear wheel for installation as defined in Figure 5.4.2.7 and 8 using 6 F5s and F3s to mount the Z26 Hub to the wheel.

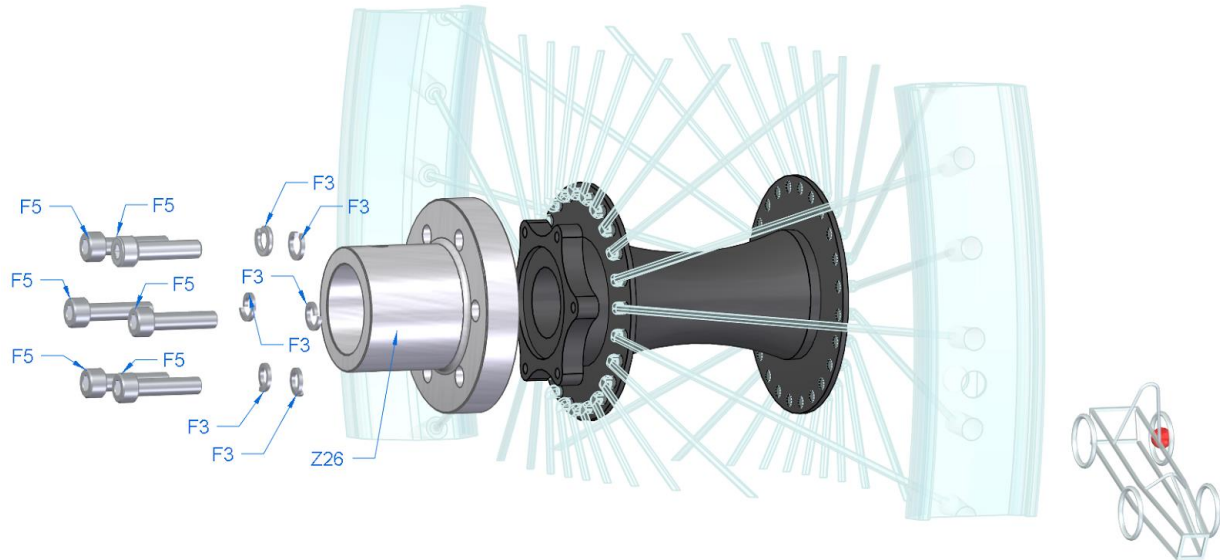


Figure 5.4.2.7
Left Rear Wheel Preparation (Unassembled)

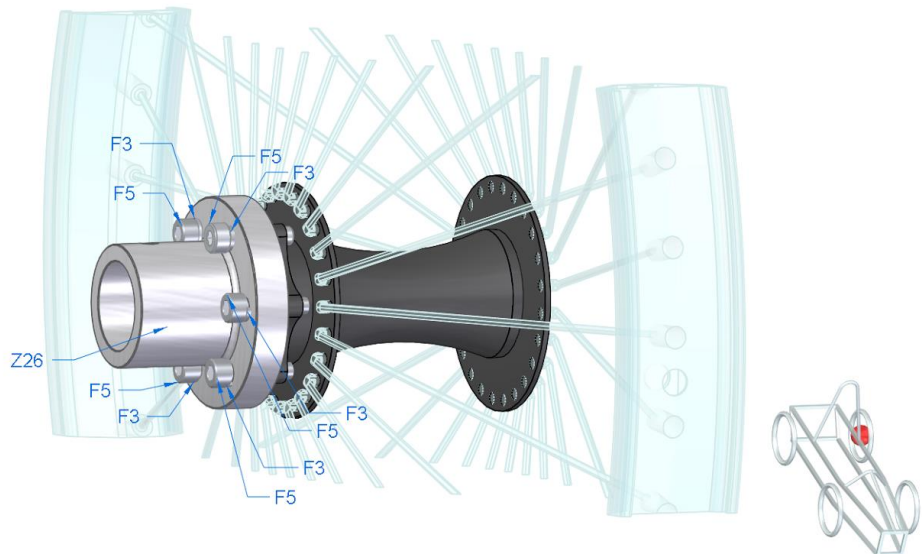


Figure 5.4.2.8
Left Rear Wheel Preparation (Assembled)

9. Install the left rear wheel onto the axle as shown in Figures 5.4.2.9 and 10. Once the hole in the Sprocket Coupling is aligned to the roll pin hole in the axle (approximately 13 inches from the end of the axle), insert the Roll Pin (F23) through the coupling and the axle. This will lock the drive sprocket onto the axle.

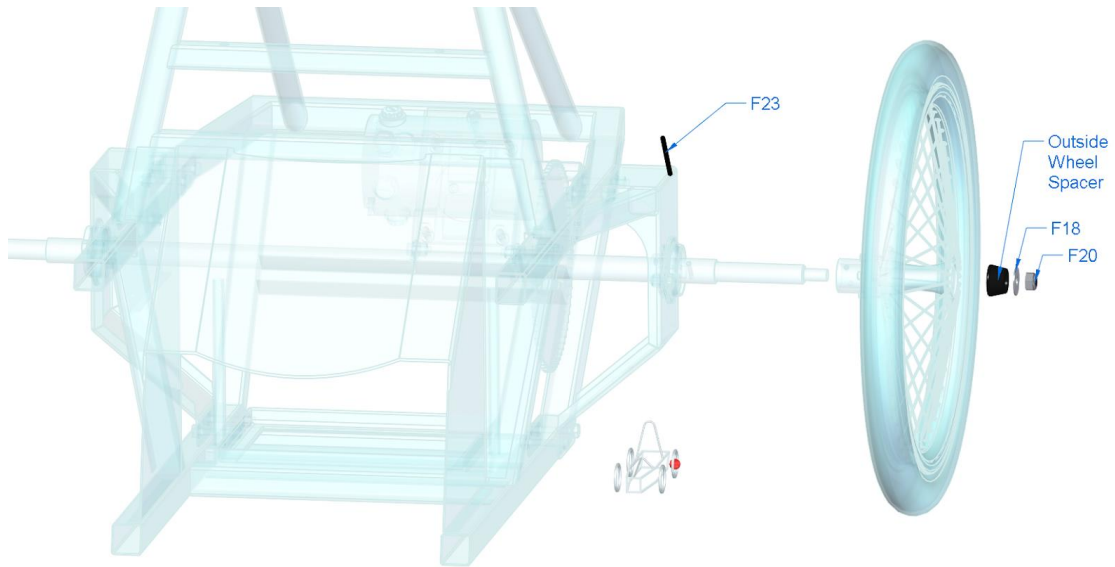


Figure 5.4.2.9
Left Rear Wheel Installation (Unassembled)

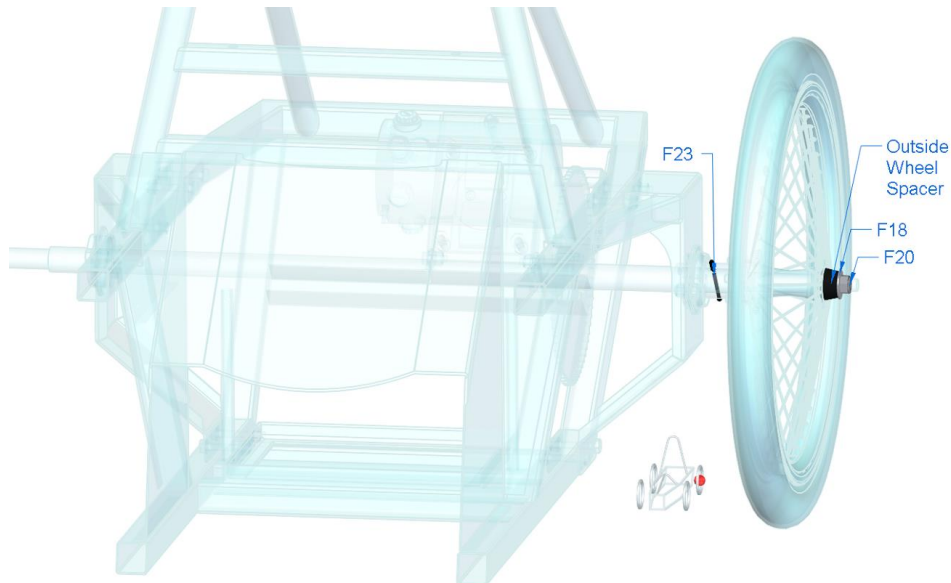


Figure 5.4.2.10
Left Rear Wheel Installation (Assembled)

10. Install the right rear wheel as shown in Figures 5.4.2.11 and 12 using an inner and outer hub spacer, an F18 and an F20.

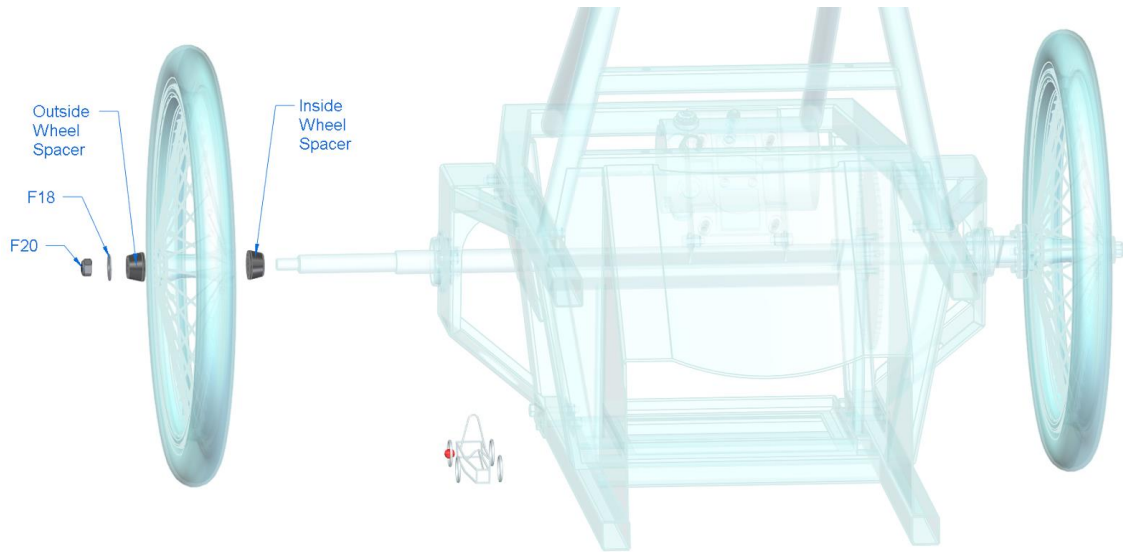


Figure 5.4.2.11
Right Rear Wheel Installation (Unassembled)

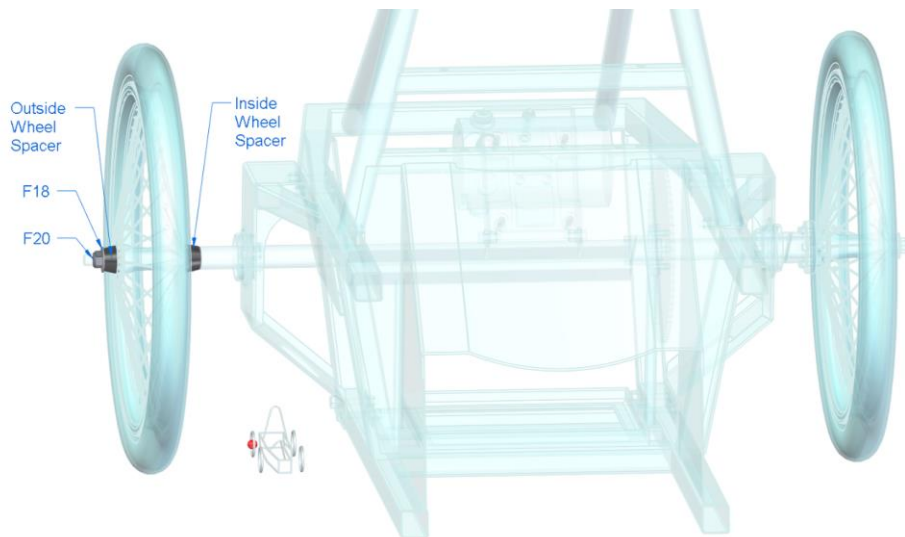


Figure 5.4.2.12
Right Rear Wheel Installation (Assembled)

5.5 Supporting Activities

Build Phase

Get it in Gear (6RP.1,2,3; CCRA-SL-R5; 6NS.1; 6EE.9; 6SP.4; 7RP.1,2,3; 7EE.4; 7NS.2,3; 7G.4; 8SP.1; A-CED1,2)

- Students will research the concept of gears on the internet. An excellent explanation is provided on the internet in the Gear Basics video from Science OnLine.
- Students will research mathematical gear calculations to understand the relationship between gears of different diameter and tooth number.
- Create a drivetrain with two rods and two “gears”. Anything that fits the description of a rod and a gear, for example, pencils and spools with a rubber band can be used. Have students investigate how turning one wheel (the driver wheel) effects the turning of the other wheel (the follower) when the wheels are not the same diameter.
 - Explore direction change with multiple gears.
 - The investigation should collect data to show the relationships between circumference ratios, revolution ratios, etc.
 - A great example can be found in the Power of the Circle from Learner.org: http://www.learner.org/workshops/algebra/workshop8/w8_power_circle.pdf
 - Students can further this exploration by extrapolating to larger gear sizes.

All Aboard the Drivetrain (TE6-8.9,11; TE9-12.6,9,11,12; L6-8.4,6; L9-10.4,6; W6-8.1,2,6,8,9; W9-10.1,2,6,8,9; CCRASL-W1,2,6,8,9; SL6-8.1,3,4,5; SL9-10.1,3,4,5; RI6-8.4,7; RI9-10.4,7; CRASL-R4,R5; PS8.9)

- Use the internet to explore a variety of drive train mechanisms and how they transfer power from the motor to the wheel. Key search terms include: direct drive, belt drive, shaft drive, screw drive, and micro drive.
- Students can present their findings in various ways, citing appropriate resources. Focus on the benefits of each type. Students will present images, drawn by hand or on-line. Discussion can follow.

Which Simple Machines Can You Find? (PS8.9,11)

- Students identify simple machines within the car and explain the purpose of each.
- Students identify pairs or sets of simple machines in the car and how they are combined to perform a task.
- Encourage students to think outside the box and discover hidden simple machines.

Name that Gear Ratio (6RP.1,2,3; 6NS.1; 6EE.9; 6SP.4; 7RP.1,2,3; 7NS.2,3; 7EE.4; 7G.4; 8SP.1)

- Using pictures from different drivetrains, students calculate the gear ratio for the F24.
- For enrichment, use systems that involve more than two gears.

Post Build

Pull Your Chain (TE6-8.5,11; W6-8.6; W9-10.6; CCRASL-W6; 6SP.4; 6SP.5; 8EE.5; 8SP.1; PS8.1,9)

- Using procedures defined in Unit 9 Driving, Data Collection and Analysis, students will complete data collection runs that involve adjusting the chain tension and determine its effect on performance.
- Students display data in a scatter plot or other type of graph.

Turning Up the Heat (TE6-8.5,11; TE9-12.5,12; W6-8.6; W9-10.6; CCRASL-W6; 6SP.4,5; 8EE.5; 8SP.1; PS8.1,9,11)

- After driving, students measure the temperature of the motor using a scale system (1-10) or an infrared thermometer.
- Students can graph the change in temperature in relation to the time driven.

- Discuss the Law of Conservation of Energy with students as it pertains to the car. For example, the car takes electrical energy and converts it to other types of energy.

Define a Concept with words (W6-8.1, W6-8.2, W6-8.9; CCRA-SL-R7; PS8.9; PS9-12.12)

- Students can explain, in their engineering notebook, how the motor makes the tires turn. Students should define this in terms of converting one form of energy to another and identifying simple machines involved. Putting their perception of the concepts into words will help deepen their understanding. This writing activity can include supporting diagrams. However, the actual writing should be detailed, explaining how one component in turn causes another to function.

5.6 Teacher Recommendations

- Since care must be taken when installing parts onto the axle, it is a good idea to call in experienced persons to guide you.
- To place the roll pin through the axle, the axle and sprocket must be aligned. It is helpful to line them up with a skinny screwdriver first.
- If the chain is not aligned to move in a smooth line, the chain can jump off the sprockets or pull the motor out of alignment. If the chain is too tight or loose, it can catch, bind, or snap.
- The chain tolerance should allow approximately $\frac{1}{4}$ inch slack up or down.
- Students who do not understand a set screw can place it into the slot upside down. Instruct the students to inspect the screw carefully noting the end with the hex slot that allows for tightening with a wrench.



Unit 6: Electrical Components

6.1 Reference Standards

Note that these standards will be applied throughout this unit. For the complete standard, please see Appendix A.

Writing Standards

- W6-8.1, W9-10.1, CCRASL-W1 (Write arguments to support claims)
- W6-8.2, W9-10.2, CCRASL-W2 (Write informative or explanatory text to convey concepts)
- W6-8.4, W9-10.4, CCRASL-W4 (Produce clear and coherent writing)
- W6-8.5, W9-10.5, CCRASL-W5 (Develop and strengthen writing by editing)
- W6-8.9, W9-10.9, CCRASL-W9 (Draw evidence to support writing)
- W6-8.10, W9-10.10, CCRASL-W10 (Write routinely for discipline-specific purposes)

Math Standards

- 8SP.1 (Construct and interpret scatter plots)

Science Standards

Physical Science (8th)

- PS8.11 (Effects on electric forces)

Physical Science (9-12)

- PS9-12.10 (Simple series and parallel circuits)

Technology Standards (Alabama)

- TE6-8.5 (Use basic features of productivity software)
- TE6-8.11, TE9-12.12 (Use digital tools to synthesize information)
- TE9-12.5 (Use advanced features of spreadsheets)
- TE9-12.16 (Create products that integrate info from multiple software application)

6.2 General Overview

In this unit, the electrical components will be installed. The wiring diagram should be followed to complete this task. In the post-build phase in conjunction with data runs in Unit 9, electrical concepts that impact the car and its performance will be explored.

Objectives

In this unit, students will:

- Install the seat belt of the F24.
- Install the electrical components.

- Run wiring needed for all components.
- Prepare batteries for operation.
- Demonstrate proper installation of batteries for driving.
- Install the brake light.

Key Vocabulary

- Circuit
- Current
- Fuse
- Relay
- Switch
- Terminal
- Voltage

Pacing

Allow approximately 2 weeks for the initial build activity. Battery exploration will occur post build concurrently with test runs in unit 9.

6.3 Materials and Tools

Table 6.3 Electrical Component Assembly Materials Tools

Tool	Description
Safety Glasses	Always wear safety glasses when working around the car
Wire cutters/ strippers	For exposing the end of the wire when making connections
Wrenches/ Sockets	For tightening wire to connectors
Electrical Tape	For wrapping exposed connections when complete
Hand Drill with 8mm bit	To enlarge the hole in the mounting hole in the Junction block

6.4 Unit Procedures

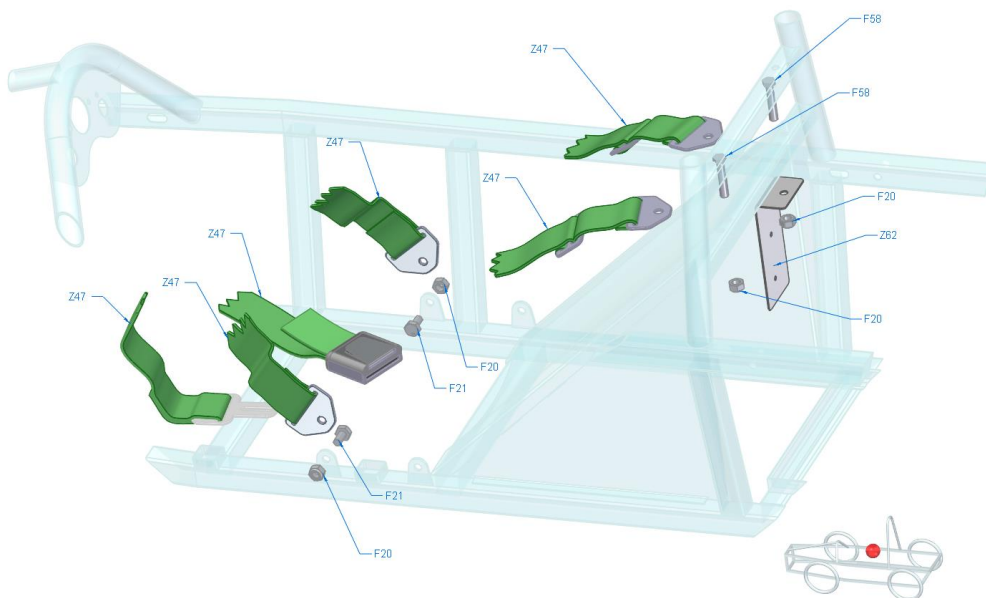
Table 6.4 Electrical Component Parts

Part Number	Quantity	Description
F5	4	M5 x 20mm Socket Head Screw
F6	4	M6 Washer
F7	3	M6 Nyloc nut
F9	1	M6 x 20mm Hexhead screw
F20	4	M10 Nyloc nut
F25	4	Rubber Grommets
F26	2	M4.5 Battery Pin
F56	2	M5 Nyloc Nut
F58	2	M10 50mm Socket Head Screw
K61	1	Fuse holder
K62	1	60 amp Fuse strip
Z31	1	Battery Isolator Switch (3 pieces)
Z32	1	Relay
Z35	2	Push Button (Throttle and Horn)
Z36	1	Horn
Z37	1	Brake Light
Z38	1	Brake Light Bracket (with screws, washers and nuts)
Z39	2 pair	Quick Release Terminal (positive and negative are indicated)
Z43	2	12 Volt Battery
Z44	1	Battery Clamp Strip
Z47	1	4-point Safety Harness, left and right halves
Z60	1	Fuse Box, four-way
Z61	3	5 amp Blade Fuses
Z62	1	Fuse Box mounting plate

Z63	1	Joining Block
	2	Spiral wrap tubing – large and small

Procedure

1. Install the safety harness system, Z47, following the illustration in Figure 6.4.1. Note that Z62, the fuse box mounting plate is installed under the right shoulder harness. There are two points of application for the lap belt portion of the harness. Choose the one most suited to having the 4-point lap belt cross the hip/lap structure not the waist of the driver.



**Figure 6.4.1
Safety Harness Assembly (Unassembled)**

2. Install the electrical components as illustrated in Figure 6.4.2 below.
 - a. The Fuse box, four-way is attached to the electronics mounting plate, Z62 with 2 F5 socket head screws.
 - b. The K61, Fuse holder, is mounted to the electrical mounting plate, which was installed in section 5.4. Use 2 F5 socket head screws. Place one 60 amp fuse strip (K62) into the fuse holder.
 - c. Install the motor relay, Z32, to the electronics mounting plate on the right side using 2 F9 hex head screws.
 - d. Install the joining block, Z63, to the electronics mounting plate. Note that you will need to use a hand drill to drill out the current mounting holes on the Z63 to 8mm. The mounting screw to use for this part is the F17, F13 and 2F8s which were installed when the rear axle bracket/mounting plate were added in 5.4. You will need to remove those parts, insert them also through the Z63 hole then reinstall. These parts are listed with an *r* in the diagram purely for reference.
 - e. Install the brake light, parts Z37 and Z38, as shown in Figure 6.4.2. Note that the wiring for the brake light was put in place in Unit 6. It may be necessary to drill

holes in the space frame to install this light. Be sure to drill through both sides of the space frame.

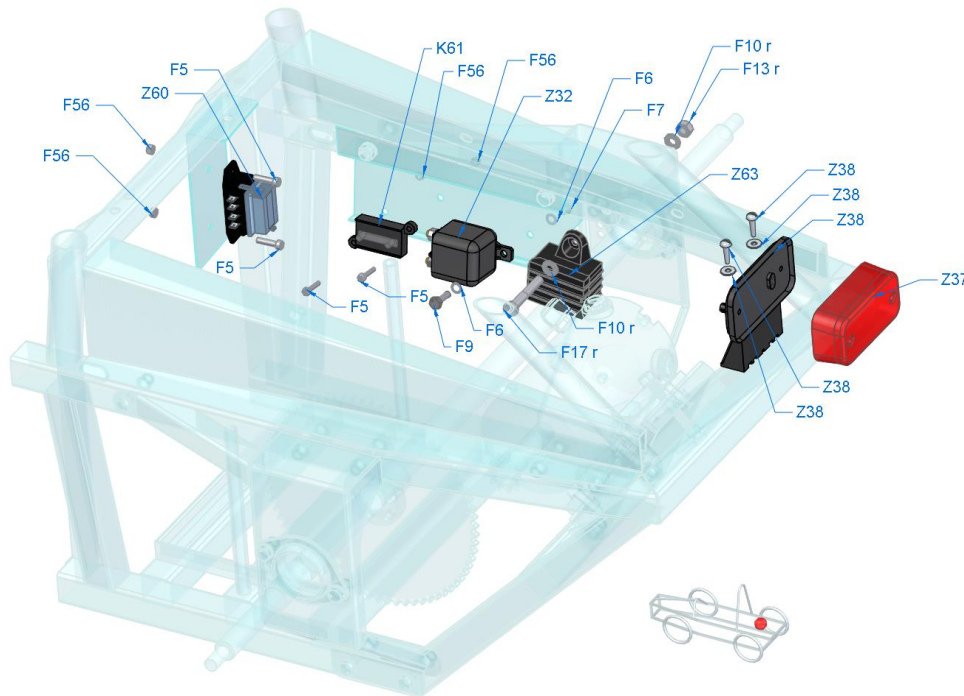
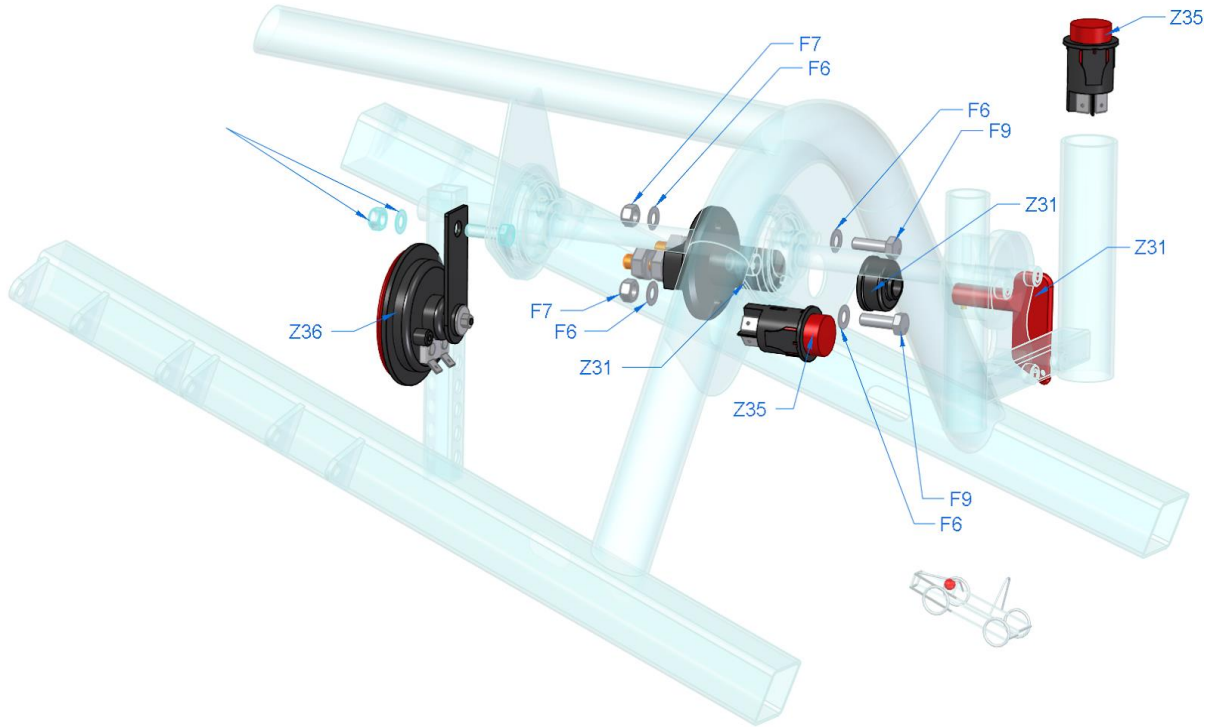
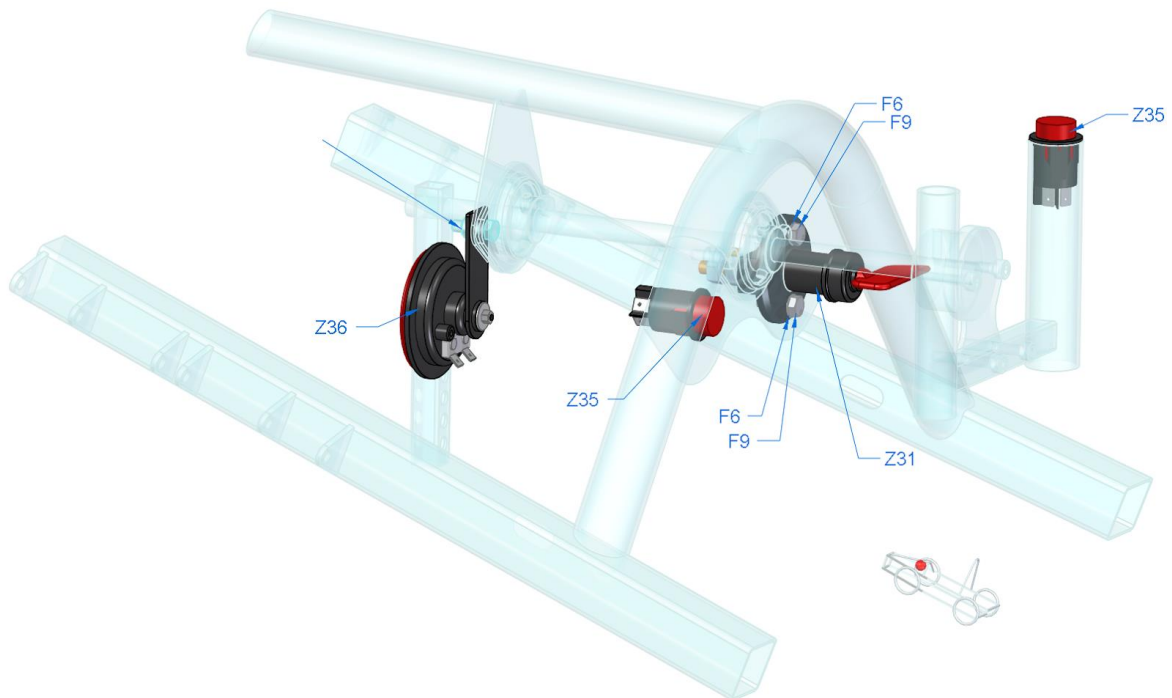


Figure 6.4.2
Electrical components Assembly

3. Install the driver controls:
 - a. The Horn (Z36) is attached to the steering column bearing plate as shown in Figures 6.4.3 and 6.4.4. Loosen the Nyloc Nut securing the left-side of the lower Steering Column bearing and secure the Horn assembly.
 - b. Install the Horn and Throttle buttons as shown. These buttons slide into the indicated positions and snap into place.
 - c. Install the Battery Isolator Switch Z31 (for the key the red portion of Z31) as shown. It is recommended from this point on, the instructor keep the key in a safe place.



**Figure 6.4.3
Horn, Button and Switch Installation (Unassembled)**



**Figure 6.4.4
Horn, Button and Switch Installation (Assembled)**

- Figure 6.4.5 is the wiring diagram as seen in industry standards. It makes a handy reference to see the paths of the wires. Figure 4.6.4 and following images show the wiring

as it runs in the actual car. Wires are labeled with letters that correspond to the diagrams. Wires will be passed through holes in the frame. Protective grommets need to be put in place to prevent wires from chaffing as shown in Figure 6.4.7.

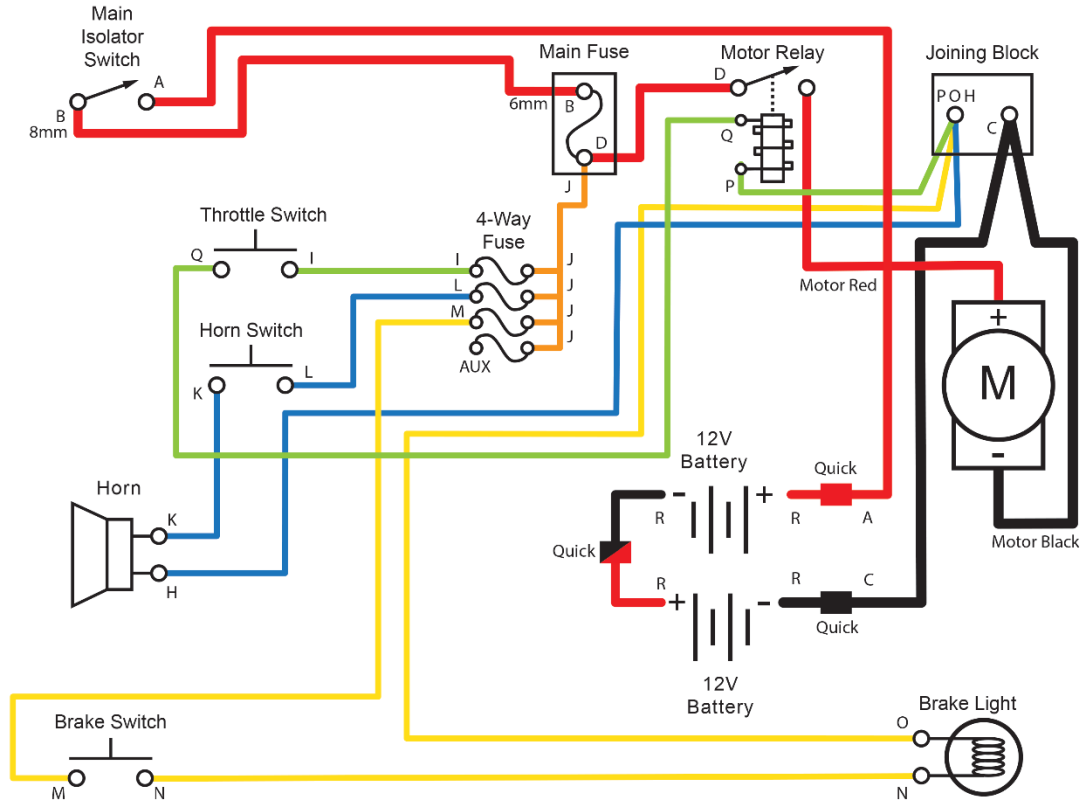


Figure 6.4.5
Wiring Diagram

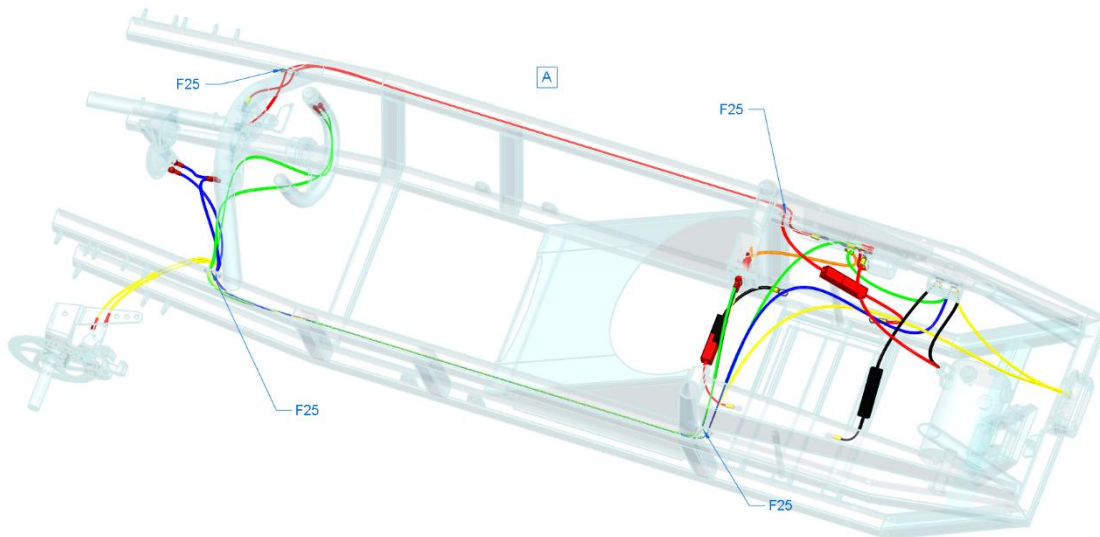
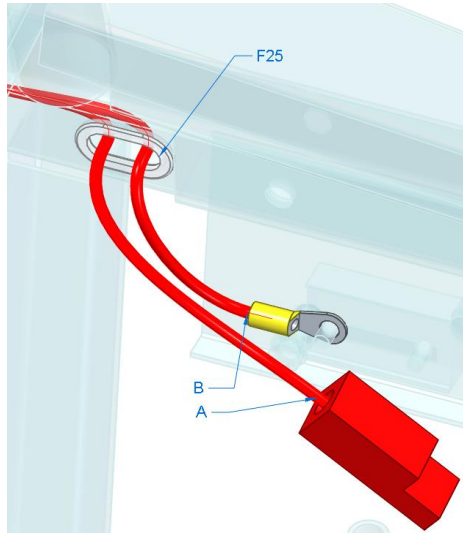
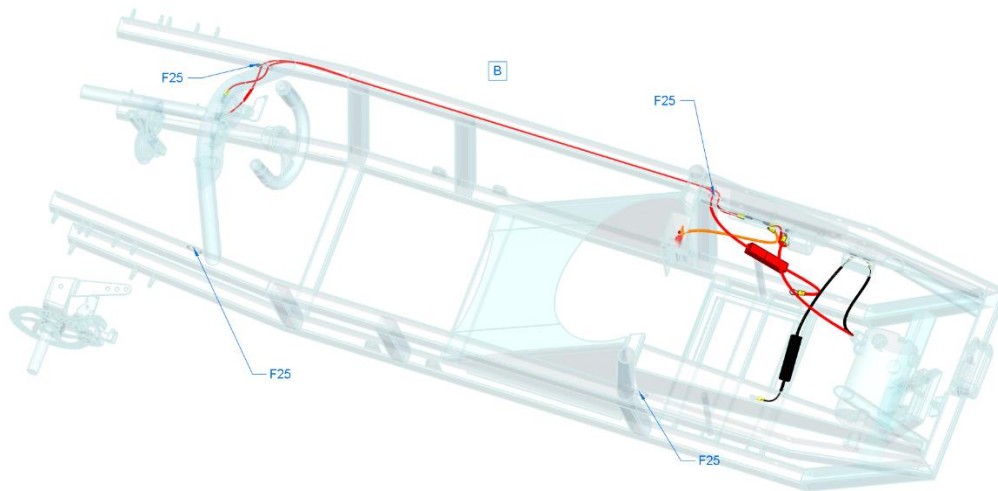


Figure 6.4.6
Complete Wire Installation



**Figure 6.4.7
Grommet Installation**

- a. Driver right side wire bundle as shown in Figure 6.4.8:
 - i. Red wires A and B will be passed through the frame from the back right to the front right frame hole. Spiral wire wrap tubing is provided to bundle these together – use the larger of the two provided tubing.
 - ii. Red wire A: Isolator switch to battery quick clip - this will attach to one of the main isolator switch's terminals. The quick clip will be attached later when the battery is installed.
 - iii. Red wire B: Isolator switch to the Fuse Holder K61 - When running this wire through, note that the end with the larger ring connects to the other isolator switch terminal. Use the left terminal of the Fuse holder for the other end.



**Figure 6.4.8
Right Side Wire bundle**

- b. Driver left side wire bundle:
- i. Use the smaller spiral wire tubing to bundle each pair of wires by color. You will need to cut this tubing. The Green bundle is in Figure 6.4.9. The blue bundle is in Figure 6.4.11 and the yellow bundle is in Figure 6.4.12.
 - ii. Green wire I: Throttle switch to 4-way fuse – The wire connects to either terminal on the throttle switch and the left side of the 4-way fuse.
 - iii. Green wire Q: Throttle switch to motor relay – The wire connects to the other terminal of the throttle switch and the left side of the 4-way fuse.
 - iv. Blue wire H: Horn to Joining Block – The wire's red terminal connector end attaches to one terminal of the horn and the ring end connects to the left terminal inside the Joining Block.
 - v. Blue wire L: Horn switch to 4-way fuse - The wire connects to the other terminal on the horn switch and the left side of the 4-way fuse.
 - vi. Yellow wire M: Brake switch to 4-way fuse - The wire connects to the NC terminal (labeled on the back side of the switch) of the brake switch and the left side of the 4-way fuse. See Figure 6.4.10.
 - vii. Yellow wire N: Brake switch to brake light – The red terminal connector attaches to the COM terminal on the brake switch and the bare end is wired to the light. Strip the wire and insert it into the red screw terminal located inside the brake light. You will need to insert the wire through the back of the black light cover then unscrew the outer screw, insert the bare wire and tighten the screw.

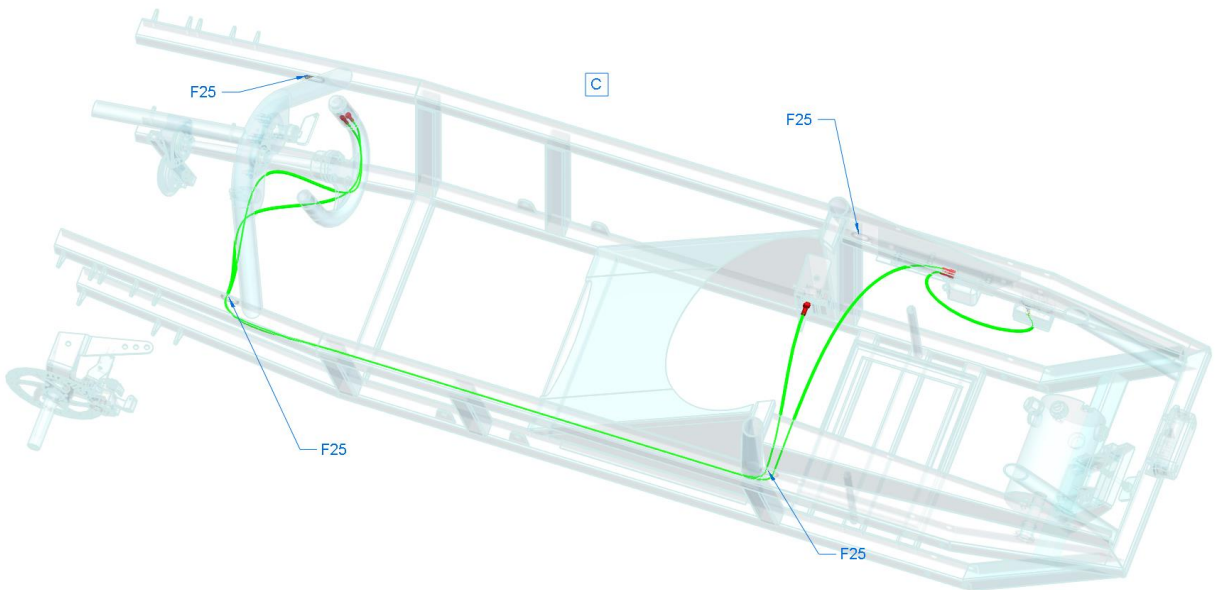
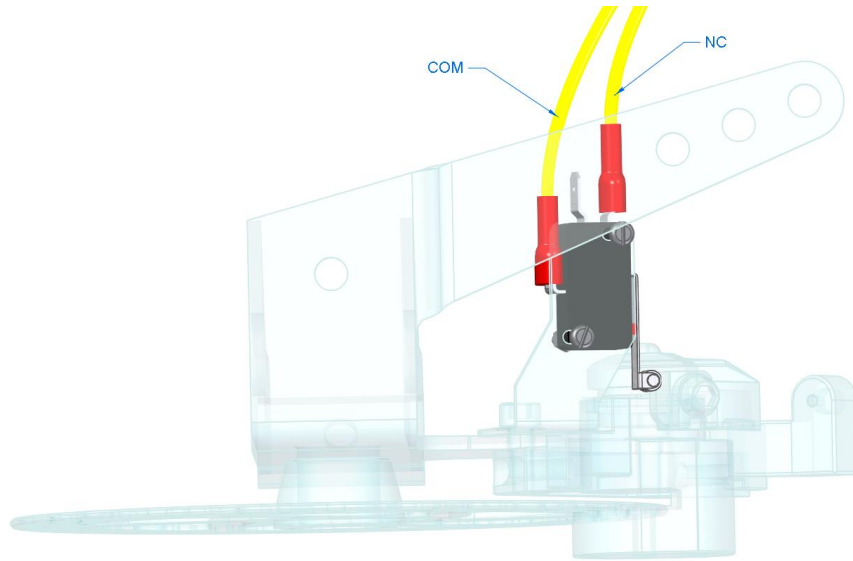
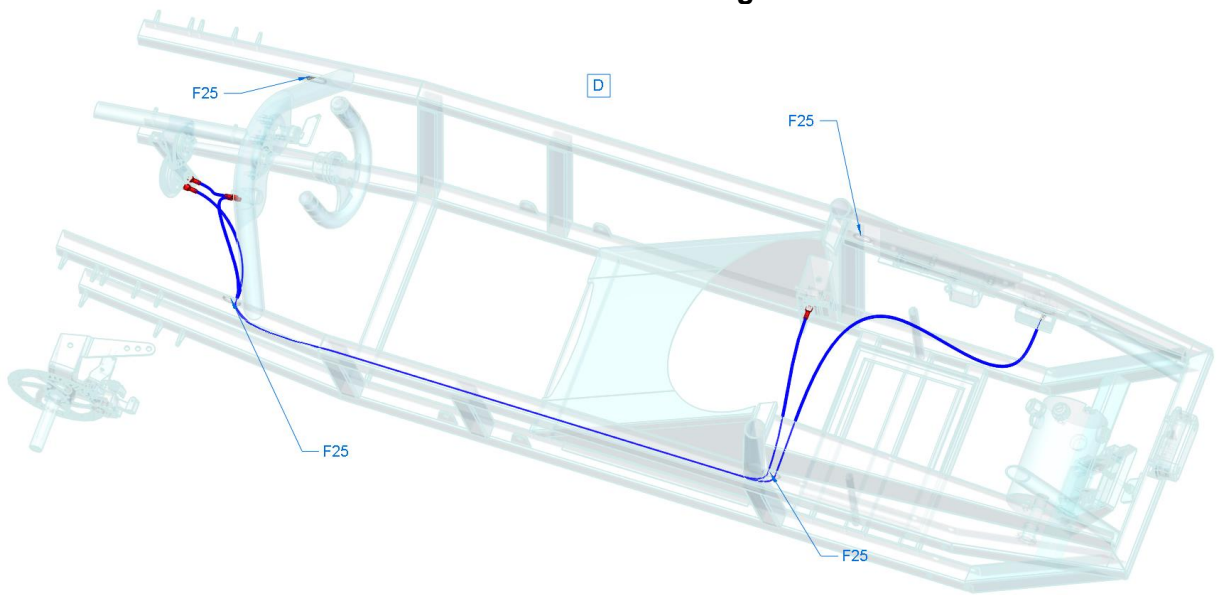


Figure 6.4.9
Left Side Green Wire bundle



**Figure 6.4.10
Isolator Switch Wiring**



**Figure 6.4.11
Left Side Blue Wire bundle**

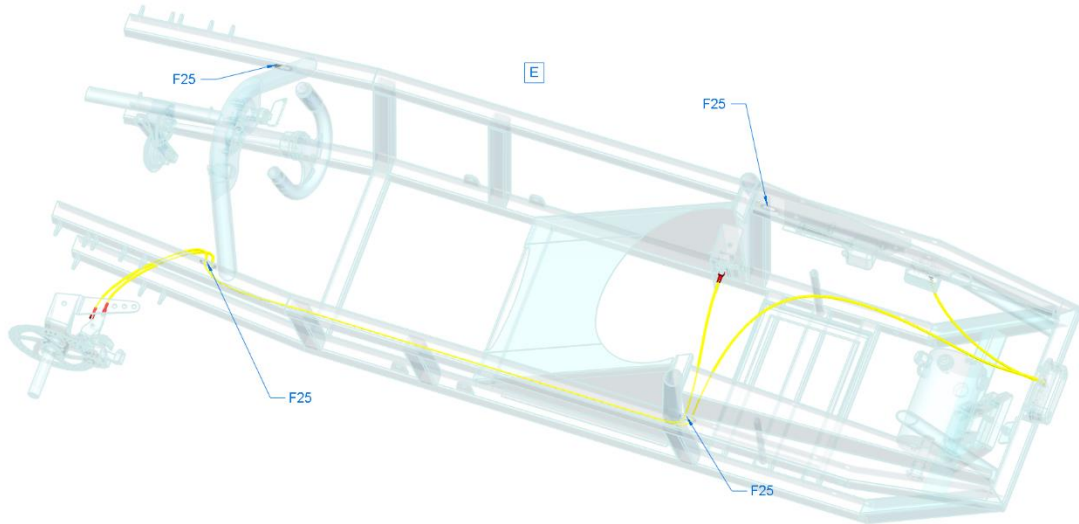


Figure 6.4.12
Left Side Yellow Wire bundle

- c. Other Wire connectors:
 - i. Red connector D: one end connects to right terminal of the fuse holder (K61) and the other to the left terminal of the relay. See Figure 6.4.8.
 - ii. Green connector P: the red terminal connector end connects to the motor relay and the ring end connects to the Joining Block's left terminal. See Figure 6.4.9
 - iii. Blue connector K: one end slides on the open terminal of the horn and the other slides on the open terminal of the horn switch. See Figure 6.4.11
 - iv. Yellow connector O: Strip the bare end of the wire and insert it into the black screw terminal located inside the brake light. You will need to insert the wire through the back of the black light cover then unscrew the outer screw, insert the bare wire and tighten the screw. The other end connects to the left terminal of the Joining Block. See Figure 6.4.12

- d. Battery Connections:
 - i. Use the screws and washer on the battery terminals to screw down the 2 red and 2 black Quick connectors (Z39) to the batteries. The red connects to the positive pole and the black to the negative pole of each battery. See Figure 6.4.13. **Do not allow anything to touch both the positive and negative terminals of the battery. This includes metal items, arms, hands, tools...**
 - ii. The batteries (Z43) are placed in the battery compartment and clamped down as follows: the Z44 battery clamp strip is placed over the two tubes rising from the battery support compartment. The F26 ring Battery Pins are then opened, slid through the slot at the top of the tubes and closed until they snap tight.

- e. Place 5 amp fuses into the 3 ports of the 4-way Fuse box.

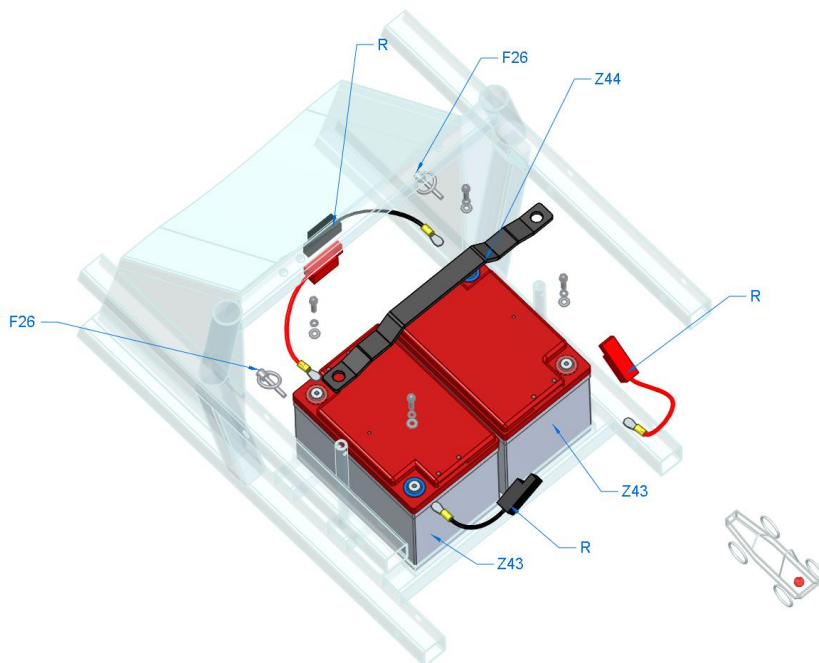


Figure 6.4.13
Battery Connections

6.5 Supporting Activities

Build Phase

Multi-meter Merriment (PS8.11; PS9-12.10)

- The following website provides a lesson on using a multi-meter:
<http://www.sciencebuddies.org/science-fair-projects/multimeters-tutorial.shtml>
- Students compare the voltage between new and used batteries. Vary the size and shape.

Shine On! (PS8.11; PS9-12.10)

- Give each group of students two lengths of wire that have the ends stripped, a D-cell battery, a flashlight bulb, and some electrical tape. Challenge them to light the bulb.

Parallel vs Series (PS8.11; PS9-12.10)

- Give each group of students two 9 V batteries, four lengths of wire with stripped ends, and a volt meter. Allow the students to explore the voltage readings when the batteries are connected positive to negative in a line (in series) vs positive to positive and negative to negative (in parallel).
 - Search the internet for diagrams of batteries in parallel vs. series and look at the images for examples.

Battery Basics (PS8.11; PS9-12.10)

- Give each group of students six pennies, six nickels, a saltwater solution (1 Tablespoon to 4 ounces water), 1 paper towel sheet, electrical tape and a voltmeter. Students will cut 12 circles from the paper towel that are slightly smaller than the nickel and then soak them in the saltwater solution. Students then form a stack in the following order: penny, paper

circle, nickel, paper circle, penny, paper circle, etc., ending with a nickel. Students then tape a bare wire end to each end of the stack and then tape the stack into a column that cannot fall apart. This forms a battery made of six “cells”. The salt water is the electrolyte solution that encourages the reaction between the different metals - copper and nickel, causing electrons to move or “flow” as a current. Students then measure the voltage by attaching the voltmeter to each of the wire ends.

Post-Build Phase

Battery Life (TE6-8.5,11; TE9-12.12; 8SP.1; PS8.11; PS9-12.10)

- Using procedures defined in Unit 9, Driving, Data Collection and Analysis, students will perform data collection runs varying the weight of the driver so voltage usage changes can be observed.
- Students display data in a scatter plot or other type of graph.
- Data collection runs made in Unit 9 can measure voltage changes so students see the kinds of things that affect battery life.

Rock My Lab Report (W6-8.1,2,4,5,9,10; W9-10.1,2,4,5,9,10; CCRASL-W1,2,4,5,9,10)

- Many of the activities in this unit are essentially science experiments. Students will log the activity in their engineering notebook as a lab report, using the scientific method. Students will begin by stating the hypothesis, what is expected, and the purpose of the testing. They will list the set-up components and steps of the process. Next, they will state the results, both visually and verbally. They will then discuss how these findings translate to the car’s performance.

6.6 Teacher Recommendation

- If possible, have an electrical engineer assist with the wiring process, Students will benefit from his or her expertise.

The graphic features the text 'Unit 7: Safety Components' in a large, black, sans-serif font. The number '7' is stylized with a blue swoosh that extends to the right, ending in a blue arrowhead. The word 'Safety' is in a smaller font size than 'Unit 7:'. The word 'Components' is in the same font size as 'Unit 7:'.

Unit 7: Safety Components

7.1 Reference Standards

The following standards will be applied throughout this unit. For the complete standard, see Appendix A.

Writing Standards

- W6-8.1, W9-10.1, CCRASL-W1 (Write arguments to support claims)
- W6-8.2, W9-10.2, CCRASL-W2 (Write informative or explanatory text to convey concepts)
- W6-8.4, W9-10.4, CCRASL-W4 (Produce clear and coherent writing)
- W6-8.5, W9-10.5, CCRASL-W5 (Develop and strengthen writing by editing)
- W6-8.8, W9-10.8, CCRASL-W8 (Gather and summarize relevant, credible information)
- W6-8.9, W9-10.9, CCRASL-W9 (Draw evidence to support writing)
- W6-8.10, W9-10.10, CCRASL-W10 (Write routinely for discipline-specific purposes)

Reading Standards

- CCRASL-R5 (Analyze relationship among concepts/key terms presented in text)

Math Standard

- 8G.7 (Right Triangle Lengths in real-world problems)
- G-SRT8 (Use Pythagorean Theorem)

Science Standards

Life Science (7th)

- LS7.4 (Interaction of skeletal system)

Physical Science (8th)

- PS8.8 (Newton's three laws of motion)
- PS8.10 (Results of objects colliding)
- PS8.11 (Effects on electric forces)

Human Anatomy and Physiology

- HAP 9-12.4 (Understand the functions of the skeletal system; b. fractures)
- HAP 9-12.6 (Understand the Central nervous system a. Head trauma)

Technology Standards (Alabama)

- TE6-8.11, TE9-12.12 (Use digital tools to synthesize information)

7.2 General Overview

In this unit, the safety components of the F24 will be installed as a part of the build-phase. In addition, students will become familiar with additional safety wear regulations used during driving events. This investigation into safety is relevant here but is always of foremost importance and is therefore emphasized throughout the Greenpower curriculum.

Objectives

In this unit, students will:

- Become familiar with current technical regulations found at greenpowerusa.net.
- Understand safety harness systems - various types and the purpose.
- Install chain guard of the F24.
- Install impact foam onto the F24 and understand its purpose.
- Understand the purpose of the roll bar.
- Identify the purpose of helmets and other safety wear.

Key Vocabulary

- Concussion
- Whiplash
- Mass
- Roll bar
- Headrest
- Harness

Pacing

Allow approximately 2 weeks for the installation of safety components and the supporting activities.

7.3 Materials and Tools

Table 7.3 Safety Component Assembly Materials and Tools

Tool	Description
Safety Glasses	Always wear safety glasses when working around the car
Duct Tape	For applying foam to the frame and headrest
Screwdrivers	For tightening brake light bracket screws
Exacto Knife/ Cutting Blade	For cutting Closed Cell foam to apply inside frame

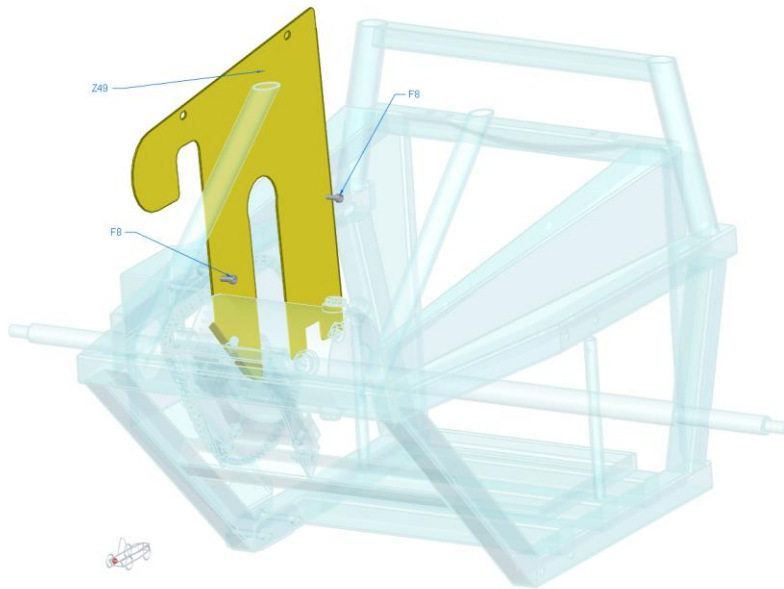
7.4 Unit Procedures

Table 7.4 Safety Component Parts

Part Number	Quantity	Description
Z46	2	Mirror on clip mount
Z48	Cut to fit	Closed Cell foam
Z49	1	Chain Guard
F8	2	M5 x 12mm Socket Head Screw

Procedure

1. As per regulation, foam must be applied on the driver's side of the headrest plate. This can be attached easily with duct tape. No image is provided as this is up to your team to determine how they would like it to look.
2. The chain guard is installed to house the large axle sprocket and the chain path. It attaches inside the frame with the screws that hold the left rear axle bracket. See the illustrations in Figures 7.4.1 and 7.4.2.



**Figure 7.4.1
Chain Guard Installation (Unassembled)**

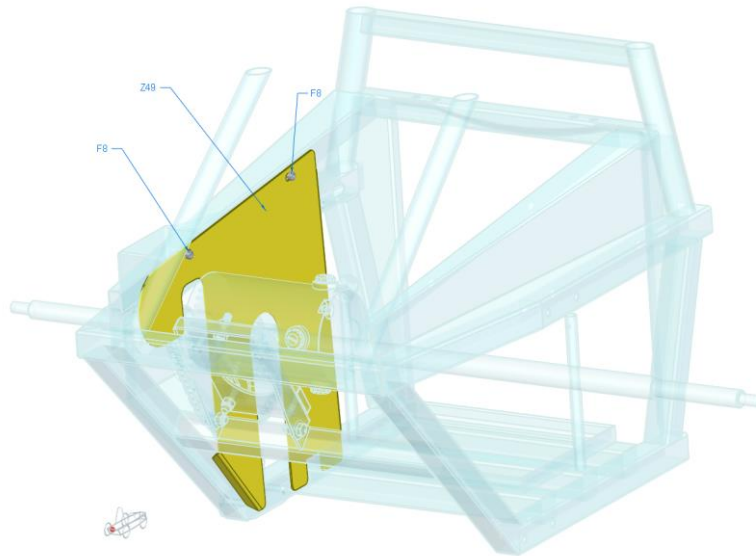


Figure 7.4.2
Chain Guard Installation (Assembled)

3. To install the side padding, cut the foam to fit within the side frame sections of the car cab and duct-tape it to the frame. See figures 7.4.3 and 7.4.4.

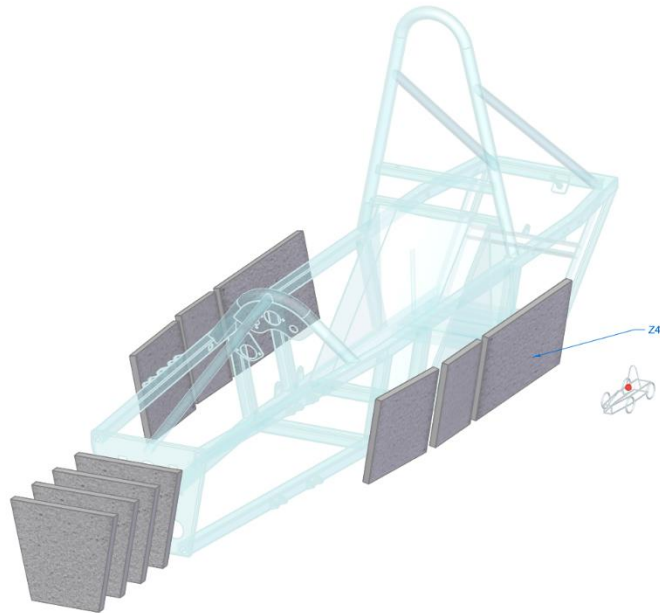


Figure 7.4.3
Closed Cell Foam Application Unassembled)

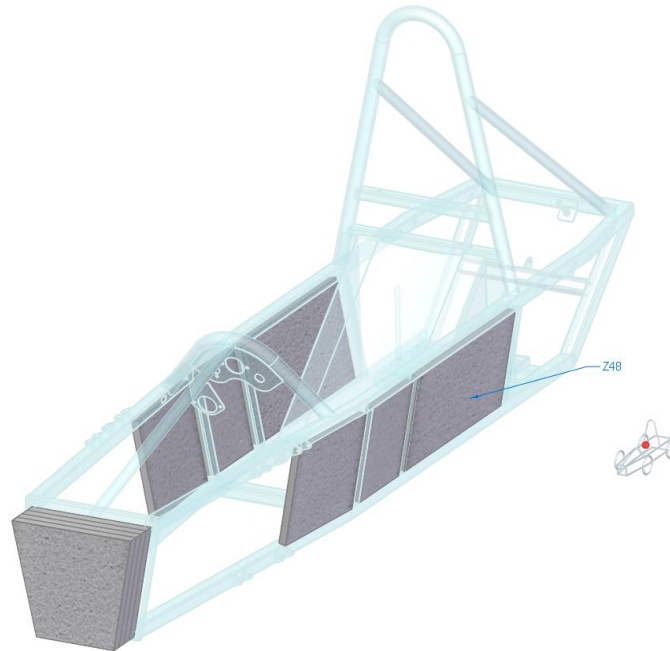


Figure 7.4.4
Closed Cell Foam Application (Assembled)

4. Install the two sideview mirrors (Z46). This component allows for team preference on placement and installation. Choose a spot which provides the best view to the rear left and right of the car from the driver's point of view. Keep in mind any racing regulations which apply. It has a clip mechanism but can be screwed on for security after desired placement is determined.

7.5 Supporting Activities

Crash! (PS8.8,10; HAP9-12.4,6)

- Students investigate forces that occur during sudden stops:
 - Place a ball or toy car (facing forward) on a skateboard. Set an object in front of the skateboard. Push the skateboard forward until there is a sudden impact with the object. Discuss/write what happens to the ball/toy car.
 - Have students explain how this enforces Newton's First Law of Motion.
 - Students discuss what happens to a body in a moving vehicle when the vehicle stops suddenly.
- Students research the different types of safety harnesses and engage in a discussion on the differences. This could be completed in a face-to-face or an online forum. Key search terms include: 4-point, 5-point, 6-point, Cam Lock, Latch & Link, submarining.
- An excellent resource is can be found on line from OGRacing in an entry called "6 things you need to consider before buying a harness": <http://www.ogracing.com/blog/2013/02/6-things-you-need-to-consider-before-buying-harnesses/>
- Refer to GreenpowerUSA.net for videos that explain safety harnesses.

- A discussion of headrests should follow after the harness discussion. The key term Whiplash should be included. Have students explain using correct terminology what happens to the head during a sudden stop when a harness is used.
- Fill a balloon partially with water. Inflate it and tie it off. Allow students to jerk the balloon to one side and then release it. They will then observe the motion of the water. A discussion of brain concussion easily follows.

BOOM! (PS8.10,11)

- Using a piece of the impact foam from the F24, bounce a golf ball on the floor and then on the foam noting how far each bounced. Students create a diagram of how the energy flowed in each case, accounting for compression of the foam. Some students may extrapolate that the golf ball itself compressed a bit as well “using” up some of the energy. An additional activity could be experimenting with various types of foam to see bounce results.
- Refer to GreenpowerUSA.net for videos that explain this concept.

On A Roll...Bar (8G.7; G-SRT8)

- During a group discussion students create two lists: situations that cause a car to roll and why a roll bar is needed. Include strength, positioning and size. Allow for online research.
- Students design their own roll bar or roll cage systems and present the concept to the class for group critique.
- Review the Technical Regulations on the roll bar. Have students explain why the driver’s height is limited using the concepts of right triangles to draw and define the space protected by the roll bar.

Hey, I’m the only me I got! (PS8.10,11)

- Since helmets are designed to absorb impact, they can be discussed after an activity such as the one above (*BOOM!*) where impact absorption is explored.
- You can refer to GreenpowerUSA.net for videos that explain this concept.
- Rub a pencil eraser across a pavement or sidewalk. Students explain why there are eraser crumbs. What is happening? Discuss how the Law of Conservation of Energy applies to protecting arms and hands from the pavement in a crash. Something has to give and the pavement will not be it! Research terms such as Road Rash.
- Review Sporting Regulations S1 - Team clothing on GreenpowerUSA.net.

Look out! (PS8.10)

- Choose a student as the leader; instruct him privately, that during this activity he is to stop walking suddenly without warning. Line students up in a front to back line and have them follow the leader closely as he moves across the room. When the leader stops, students will bump into one another. Follow this with a discussion about the importance of brake lights. Discuss color and any other features that make their use important. Students discuss if use of the horn is a safety feature.

The First Law states... (W6-8.1,2,4,5,8,9,10; W9-10. 1,2,4,5,8,9,10; CCRASL-W1,2,4,5,8,9,10)

- In the engineering notebook, students explain the concept of Newton’s First Law of Motion as it applies to objects in motion and what happens when they are forced to stop suddenly. Students should support their explanation with examples from any of the activities completed in section 7.5. Their conclusion should explain how this applies to the Greenpower car during a race.

7.6 Teacher Recommendations

- The chain guard screws are difficult to reach when the guard is attached. This addition can occur late in the build process, allowing for easier chain adjustment. **However, the vehicle must not run without this guard. The moving chain can cut off a finger!**



Unit 8: Body Application

8.1 Reference Standards

Note that these standards will be applied throughout this unit. For the complete standard, please see Appendix A.

Writing Standards

- W6-8.1, W9-10.1, CCRASL-W1 (Write arguments to support claims)
- W6-8.2, W9-10.2, CCRASL-W2 (Write informative or explanatory text to convey concepts)
- W6-8.4, W9-10.4, CCRASL-W4 (Produce clear and coherent writing)
- W6-8.5, W9-10.5, CCRASL-W5 (Develop and strengthen writing by editing)
- W6-8.9, W9-10.9, CCRASL-W9 (Draw evidence to support writing)
- W6-8.10, W9-10.10, CCRASL-W10 (Write routinely for discipline-specific purposes)

Technology Education Standards (Alabama)

- TE9-12.9 (Ethical use of digital content, copyright)
- TE9-12.11 (Critique digital content for accuracy, bias, currency, relevance)

Math Standards

- 6G.1 (Areas of polygons and special quadrilaterals in real-world problems)
- 6G.4 (Surface area using nets)
- 7G.6 (Solve real-world problems involving surface area)
- AC-8 (Determine missing info by using right triangles)
- G-MG1 (Use geometric shapes to describe objects)
- G-MG3 (Apply geometric methods to solve problems)

Science Standards

Physical Science (8th)

- PS8.1 (Identify steps within the scientific process)
- PS8.8 (Newton's three laws of motion)

Reading Standards

- CCRASL-R1 (Cite evidence to support analysis)
- CCRASL-R5 (Analyze relationship among concepts/key terms presented in text)
- CCRASL-R8 (Distinguish among facts, judgements and speculation)

8.2 General Overview

In this unit, students will continue the investigation begun in Unit 3 concerning body design and implementation. This unit will center on applying these ideas to the actual car. The physical characteristics that exist due to wiring, roll bar, etc. will now be taken into consideration, including

ease of access to components for maintenance. Students will evaluate materials that will increase the car's performance. The safety foam addition required on the "nose" of the car will need to be incorporated into the design, as well. Your design should consider that the driver compartment must ensure driver safety. Aerodynamics should also be taken into consideration. Innovation and creativity should be encouraged when choosing body materials.

Objectives

In this unit, students will:

- Calculate an estimated surface area of the car design using nets.
- Understand shape and function as they apply to car performance.
- Understand wind resistance as a form of friction.
- Understand tradeoffs of various body materials with performance.
- Affix a nose cone to front of the car.
- Observe Aerodynamic flow characteristics via a wind tunnel (either an actual one or videos or simulations online).
- Model a car or portion of a car so its performance in a wind tunnel can be observed.

Key Vocabulary

- Aerodynamics
- Drag
- Nets (mathematical definition)
- Surface Area
- Wind Resistance
- Wind tunnel

Pacing

Allow approximately 2 weeks minimum to apply a body to the car, meeting regulations.

8.3 Materials and Tools

Tools needed in this unit will be dictated by the materials that are chosen for the body. Rigid side panels must be installed around the driver compartment. This material should be able to withstand impact with another object. An example of acceptable material is aluminum sheeting. If you choose to create a wind-tunnel, materials will be specific to your tunnel design. Software such as Siemens Solid Edge can be used to model your car.

8.4 Unit Procedures

1. Brainstorm the implementation of body design ideas discussed in Unit 3.
2. Install a nose cone that is internally composed of high density closed-cell foam. The regulations require at least 100mm of medium-high density energy absorbing flexible closed cell foam forward of the bulkhead to protect the driver from frontal impact. This should be incorporated into the nose cone design.
3. Explore different designs by using the scientific process.
 - a. Examples include wind tunnel simulation, weight analysis, material analysis, etc.

- b. Students should consider cost, performance, durability, maintenance and safety. For example, aluminum is a great material, but it can be costly and unsafe at times.
8. Once a design has been chosen, the outer layer can be added to the car.

8.5 Supporting Activities

Surface Area (6G.1,4; 7G.6; AC-8; G-MG1,3)

- Have students break the completed model into a net and find the surface area of the outer material.
- There are various tutorials online to help with this skill. Key search terms could include:
 - Surface Area using Nets
 - Nets and Relationship to Surface Area

Homemade Wind Tunnel (PS8.1,8)

- Research designs for a basic homemade wind tunnel. Have students construct a foam replica of the car, or parts of the car, and place in the wind tunnel. Students observe and critique various designs to improve the car's performance.

The Outer Layer (PS8.1,9; CCRASL-R1,R5,R8)

- Students research different materials that can be used for the outer layer of the car. Consider all properties of the materials, such as, weight, resistance to water, wind, debris, and reparability. Students should also look into cost effectiveness of all materials.

Defending our Design (W6-8.1,2,4,5,9,10)

- All team members should be able to verbally defend the team's design decision. In their notebook, students should write a design defense that explains all choices and why they were made. The "why" description should have some scientific basis or sound engineering concepts that have been explored i.e. aerodynamics, weight distribution, safety, functionality, etc.

8.6 Teacher Recommendations

- This unit varies drastically from team to team. Each team needs to pay close attention to the racing regulations found on greenpowerusa.net and make sure all design ideas comply with them.
- The more sponsors you are able to acquire, the more cost options you have for materials.
- Consider putting your sponsor's logo on your car.



Unit 9: Driving, Data Collection and Analysis

9.1 Reference Standards

Speaking and Listening Standards

- SL6-8.1, SL9-10.1 (Engage in Collaborative Discussions)

Writing Standards

- W6-8.1, W9-10.1, CCRASL-W1 (Write arguments to support claims)
- W6-8.2, W9-10.2, CCRASL-W2 (Write informative or explanatory text to convey concepts)
- W6-8.4, W9-10.4, CCRASL-W4 (Produce clear and coherent writing)
- W6-8.5, W9-10.5, CCRASL-W5 (Develop and strengthen writing by editing)
- W6-8.9, W9-10.9, CCRASL-W9 (Draw evidence to support writing)
- W6-8.10, W9-10.10, CCRASL-W10 (Write routinely for discipline-specific purposes)

Math Standards

- 6RP.2 (Unit Rate)
- 6SP.4 (Display numerical Data Plots)
- 6SP.5 (Summarize numerical data in relation to their context)
- 6NS.1 (Dividing Numbers fluently)
- 6NS.2 (Add, Subtract, Multiply and divide with decimals)
- 6NS.6 (Understand rational numbers as a point on a line)
- 6NS.7 (Understand ordering of numbers)
- 6NS.8 (Solve real-world problems by graphing)
- 7RP.1 (Compute unit rates associated with ratios of fractions)
- 7NS.3 (Solve real-world problems involving the four operations)
- 7SP.3 (Assess visual overlap of two distributions)
- 7SP.4 (Draw informational inferences about two populations)
- 8EE.5 (Using slope of a graphed line)
- 8SP.1 (Construct and interpret scatter plots)
- F-IF4 (Interpret key features of a graph modeling relationship between two quantities)
- AC-5 (Determine rate of change from graphical and numeric data)
- S-ID6 (Represent data with scatter plots)
- A-12 (Model data by estimating the curve that best fits)

Technology Education Standards (Alabama)

- TE6-8.11, TE9-12.12 (Use digital tools to synthesize information)
- TE9-12.5 (Use advanced feature of spreadsheets)

Reading Standards

- CCRASL-R3 (Follow multistep procedure)

9.2 General Overview

In this unit, basic data collection procedures will be defined. These procedures will be used with the data collection/testing runs referred to in previous units as post-build activities. The data collected should be logged in spreadsheet software such as Excel, which provides needed tools for data analysis. As your team defines procedures, they should include race condition safety procedures that need to be maintained for the required level of safety at all times. This is a good job for your safety manager, if you defined one in Unit 2.

Objectives

In this unit, students will:

- Safely execute a driving run that replicates race conditions.
- Collect data from a driving test that is valid and useable for effective analysis.
- Analyze data to determine advantages and/or disadvantages of modifications to the car.

Key Vocabulary

- Lap
- Paddock
- Pit Row
- Pitstop
- Race Marshall
- Scrutineering
- Transponder

Pacing

Allow approximately 6 weeks for collecting data and making adjustments. Also, allow for a 2 week periods of preparation before each race event.

9.3 Materials and Tools

Table 9.3 Driving and Data Collection Materials and Tools

Tool	Description
Battery Charger	to recharge the battery to full status when low or starting new test runs
Computer	for data logging
Driving Helmet	meeting safety requirements
Gloves	for driver to protect fingers from pavement contact
Protective Clothing	for driver and pit crew such as coveralls, long pants, long sleeves
Stop watches	for measuring lap times

Tire Gauge	for measuring tire pressure
Tire Pump	to add air to tires
Volt Meter	to measure battery status

9.4 Unit Procedures

1. Replicate a race track environment: define a circular track and measure its distance. Set a visible starting point to ease the collection of data. Make sure the area is clear of safety hazards. Define a pit area to allow for practicing this portion of the race.
2. Research and understand race protocol and regulations.
 - a. You must pass the Scrutineering Checklist with the scrutineering team prior to event racing. You will find a copy of this checklist at greenpowerusa.net.
 - b. During an actual race, the car will be outfitted with a transponder that electronically logs each lap.
 - c. Race marshals will officiate at race events. Their job is to ensure the safety of all drivers.
 - d. In most Greenpower races, a minimum of two driver changes must occur in a race.
3. Race officials use a flag system to communicate with drivers. A detailed explanation of each flag can be found at greenpowerusa.net.
4. Practice pit stops with race event conditions:
 - a. A person, often called the Pusher, receives the car, turns off the key, and pushes the car to the pit.
 - b. Drivers are swapped out, and re-harnessed.
 - c. All drivers must be pushed to the pit marshal to have their safety harness approved each time a driver exits pit row.
 - d. Once the marshal approves the safety, the driver turns the key on and is pushed back into the race.

Your team may have access to a Paddock area where all team members reside when no one is in the pit. When a pit stop is necessary, only six members may exit the paddock and enter the pit area.

5. Establish procedure to collect valid data: once the driver begins, do not start the stopwatch until he or she crosses the marked starting point at full speed - this might even require a full circuit. Each time the driver crosses the marked point, log the reading on the stopwatch. Run several laps without stopping to provide multiple data points. When a driver stops, measure and log the voltage of each battery by placing the probes across the two terminals.

9.5 Supporting Activities

Best Driving Line (SL6-8.1; SL9-10.1; 6SP.4,5; 7SP.3,4)

- Students research professional driving lines and apply them to their own driving lines. In other words, on turns do you want to be inside or outside? On straightaways, do you want to be inside or outside?
- Drivers try different lines to see how it affects their driving time. Students record data and present their findings.

What is a Transponder? (SL6-8.1)

- All cars will be given a transponder that records times during a race. As a team, decide the best location for it. Make sure it has a clear line of sight to the signal it is transmitting to which could be on the ground.
- Transponder location is a small component but could be the difference in the race.

What's My Time? (TE6-8.11; TE9-12.12; CCRASL-R3)

- Review operating a stopwatch and the function of the various buttons. Recording lap times is a critical component when analyzing your data.
- During practices, have students record each lap time.

Speed Calculations (6RP.2,4; 6NS.1,2,6,7,8; 6SP.5; 7RP.1; 7NS.3; 7SP.3,4; 8SP.1; 8EE.5; A-CED4; F-IF4; AC-5; S-ID6; A-12; CCRASL-R3;)

- After a practice run, students use recorded data to calculate the car's speed. During this activity, students will compute speed using paper and pencil or by creating formulas in Excel to find the car's speed.
- Students can graph each driver's speed over time and see if any patterns emerge. Students can again do this with paper and pencil or spreadsheet functions.
- Advanced students can use the graph and the slope of the graph's line to predict speed.

Reading Voltages (6SP.4,5; 6NS.8; 7 RP.1; 7SP.3,4; F-IF4, AC-5; S-ID6; A-12 TE6-8.11)

- When driving, it is important to always know the voltages of the batteries. Instruct students in the operation of a voltmeter and take readings during practices.
- Students can graph voltages over time. Combining the graphs of voltages and speed together helps show important information about the car's performance. Students can also observe the voltage drop pattern as battery is depleted.

Pit Stop (6RP.2; 6SP.5; 7NS.3)

- Calculate pit stop time with a stopwatch - the faster you pit, the less time out of the race.
- Determine how to notify your driver to pit on the next lap.
- Set procedures for exiting and entering drivers. The exiting driver always leaves from one side while new drivers enter from the other.
- The Pit Crew members are assigned tasks of holding the car stationary for driver change, harnessing the new driver, and visually inspecting the car for problems.

The X Factor (refer to previous units depending upon desired changes)

- After analyzing data, you may find that some features of the car can be modified to increase its performance or resolve an issue. Some factors that could change are:
 - Tire Pressure
 - Chain Tension
 - Wheel Alignment (Toe & Camber)
 - Driver/Car Weight
 - Body Design
- If changes in these areas are desired, refer to previous units for reference and recommendations.

Reflections (W6-8.1,2,4,5,9,10; W9-10.1,2,4,5,9,10; CCRASL-W1,2,4,5,9,10)

- This unit involves driving for practice, data collection or for an event. This is an excellent place to write reflectively about the driving/racing process. Students should discuss how driving feels, what functioned well and what did not, improvements needed, etc. Remind

students this is reflective writing in an engineering setting and should state a personal opinion about the activities, not individuals. The cause of mistakes can be identified but not the blame. Good engineers write reflectively so others understand and learn from the event. The additional writing exercise mentioned in section 2.5 can be revisited at this point. Students will complete an additional reflective writing exercise where they re-read their concepts of the team and the project from the beginning and reflect on how things were the same or different from anticipated.

9.6 Teacher Recommendations

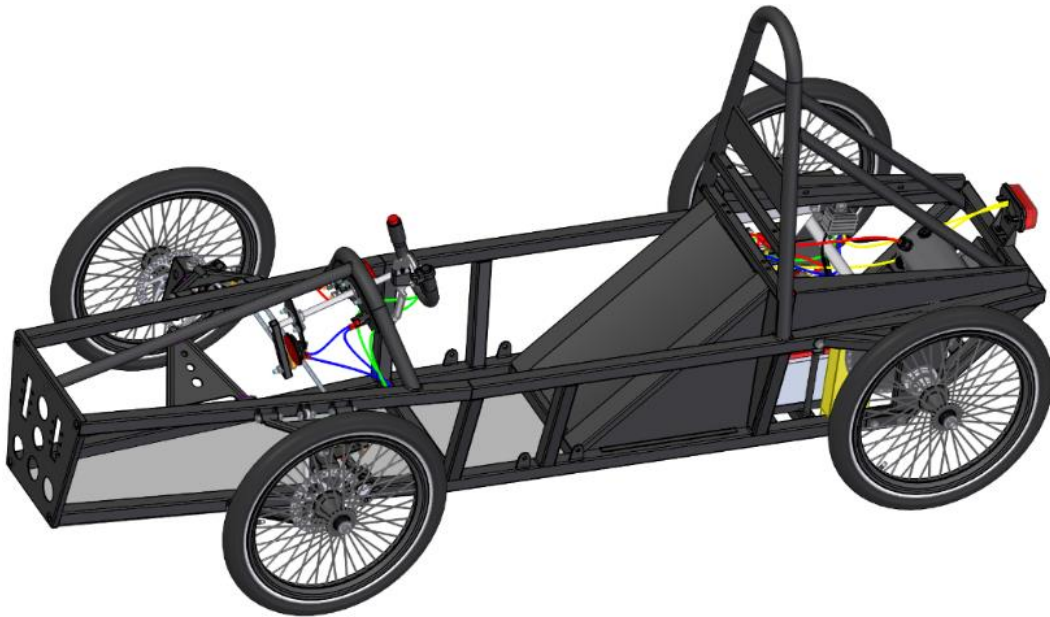
- A push is required to set the car in motion. Starting the car without a push causes a significant drop in battery voltage and puts an excessive sudden strain on the motor support structure. Three strides are recommended for the person pushing.
- Unofficial driving events where you practice with other Greenpower cars on the track are beneficial. They improve your experience base and students benefit from sharing their experiences.
- The Greenpower races can be completed in most weather conditions. It is recommended that you practice driving in all types of weather conditions. Once again, SAFETY IS NUMBER ONE! If you do not feel comfortable with the driving conditions, do not practice at that time.
- Charge the batteries after every practice. Failure to do so can result in poor performance of the batteries.
- When recording lap times, have multiple students record lap times for accuracy.
- The transponder position needs to be considered in body application. It could have an impact on your design or body application in some areas of the car. The transponder position will be referenced in the technical regulation on greenpowerusa.net.

Appendix A:

Standards

6th – 10th grade

Complete standard text, by subject



Formula 24 Series Overview Chart		Greenpower Focus	
Language Standards	Conventions of Standard English		
	L6.1 L7.1 L8.1 L9.1 L10.1	Demonstrate command of the conventions of Standard English grammar and usage when writing or speaking.	Units 1, 2
	L6.2 L7.2 L8.2 L9.2 L10.2	Demonstrate command of the conventions of Standard English capitalization, punctuation, and spelling when writing.	Units 1, 2
	Knowledge of Language		
	L6.3 L7.3 L8.3 L9.3 L10.3	Use knowledge of language and its conventions when writing, speaking, reading, or listening.	Units 1, 2
	Vocabulary Acquisition & Use		
	L6.4 L7.4 L8.4 L9.4 L10.4	Determine or clarify the meaning of unknown and multiple-meaning words or phrases, choosing flexible from a range of strategies.	Unit 5
	L6.6 L7.6 L8.6 L9.6 L10.6	Acquire and use accurately grade-appropriate general academic and domain-specific words and phrases; gather vocabulary knowledge when considering a word or phrase important to comprehension or expression.	Unit 5

Formula 24 Series Overview Chart		Greenpower Focus	
Writing	Text Types and Purposes		
	W6.1 W7.1 W8.1 W9.1 W10.1	Write arguments to support claims with clear reasons and relevant evidence.	Units 1,2,3, 5,6,7,8,9
	W6.2 W7.2 W8.2 W9.2 W10.2	Write informative or explanatory texts to examine a topic and convey ideas, concepts, and information through the selection, organization, and analysis of relevant content.	Units 2,3,4 5,6,7,9
	Production and Distribution		
	W6.4 W7.4 W8.4 W9.5 W10.5	Produce clear and coherent writing in which the development, organization, and style are appropriate to task, purpose, and audience.	Units 1,2,3, 4,6,7,8,9
	W6.5 W7.5 W8.5 W9.5 W10.5	Develop and strengthen writing as needed by planning, revising, editing, rewriting, or trying a new approach, focusing on how well the purpose and audience have been addressed.	Units 1,2 3, 4,6,7,8,9
	W6.6 W7.6 W8.6 W9.6 W10.6	Use technology, including the Internet, to produce and publish writing and present the relationships between information and ideas efficiently as well as to interact and collaborate with others.	Units 2, 3 and 5
	Research to Build and Present Knowledge		
	W6.7 W7.7 W8.7 W9.7 W10.7	Conduct short research projects to answer a question (including a self-generated question), drawing on several sources and generating additional related, focused questions that allow for multiple avenues of exploration.	Unit 3
	W6.8 W7.8 W8.8 W9.8 W10.8	Gather relevant information from multiple print and digital sources, using search terms effectively; assess the credibility and accuracy of each source; and quote or paraphrase the data and conclusions of others while avoiding plagiarism and following a standard format for citation.	Units 1,3, 4,5,7
	W6.9 W7.9 W8.9 W9.9 W10.9	Draw evidence from literary or informational texts to support analysis, reflection, and research.	Units 1, 2, 3, 4, 5, 6, 7, 8, 9

Formula 24 Series Overview Chart			Greenpower Focus
Writing	Range of Writing		
	W6.10 W7.10 W8.10 W9.10 W10.10	Write routinely over extended time frames, including time for research, reflection, and revision, and shorter time frames such as a single sitting or a day or two for a range of discipline-specific tasks, purposes, and audiences.	Units 1, 2, 3, 4, 6, 7, 8, 9

Formula 24 Series Overview Chart			Greenpower Focus
Speaking & Listening	Comprehension & Collaboration		
	SL6.1 SL7.1 SL8.1 SL9.1 SL10.1	Engage effectively in a range of collaborative discussions (one-on-one, in groups, and teacher-led) with diverse partners, building on others' ideas and expressing their own clearly.	Units 2, 3, 5, 9
	SL6.3 SL7.3 SL8.3 SL9.3 SL10.3	Delineate a speaker's argument and specific claims, evaluating the soundness of the reasoning and relevance and sufficiency of the evidence and identifying when irrelevant evidence is introduced.	Units 3 and 5
	Presentation of Knowledge & Ideas		
	SL6.4 SL7.4 SL8.4 SL9.4 SL10.4	Present claims and findings, emphasizing salient points in a focused, coherent manner with relevant evidence, sound valid reasoning, and well-chosen details; use appropriate eye contact, adequate volume, and clear pronunciations.	Units 2 and 5
	SL6.5 SL7.5 SL8.5 SL9.5 SL10.5	Integrate multimedia and visual displays into presentations to clarify information, strengthen claims and evidence and add interest.	Units 2 and 5
	SL6.6 SL7.6 SL8.6 SL9.6 SL10.6	Adapt speech to a variety of contexts and tasks, demonstrating command of formal English when indicated or appropriate.	Unit 2

Formula 24 Series Overview Chart			Greenpower Focus
Reading Informational Text Standards	Craft & Structure		
	RI6.4 RI7.4 RI8.4 RI9.4 RI10.4	Determine the meaning of words and phrases as they are used in a text, including figurative, connotative, and technical meaning; analyze the impact of specific word choices on meaning and tone, including analogies or allusions to other texts.	Units 4 and 5
	Integration of Knowledge & Ideas		
	RI6.7 RI7.7 RI8.7 RI9.7 RI10.7	Evaluate the advantages and disadvantages of using different mediums (e.g., print or digital text, video, multimedia) to present a particular topic or idea.	Unit 5
	RI6.8 RI7.8 RI8.8 RI9.8 RI10.8	Delineate and evaluate the argument and specific claims in a text, assessing whether the reasoning is sound and the evidence is relevant and sufficient; recognize when irrelevant evidence is introduced.	Unit 3
	RI6.9 RI7.9 RI8.9	Analyze a case in which two or more texts provide conflicting information on the same topic and identify where the texts disagree on matters of fact or interpretation.	Unit 3

Formula 24 Series Overview Chart			Greenpower Focus
Ratios and Proportional Relationships	Understand ratio concepts and use ratio reasoning to solve problems.		
	6RP.1	Understand the concept of ratio, and use ratio language to describe a ratio relationship between two quantities.	Unit 5
	6RP.2	Understand the concept of a unit rate associated with a ratio and use rate language in the context of a ratio relationship.	Units 5 and 9
	6RP.3	Use ratio and rate reasoning to solve real-world and mathematical problems, e.g., by reasoning about table of equivalent ratios, tape diagrams, double number line diagrams, or equations.	Units 3 and 5
The Number System	Apply and extend previous understandings of multiplication and division to divide by fractions.		
	6NS.1	Interpret and compute quotients of fractions, and solve word problems involving division of fractions, e.g., by using visual fraction models and equations to represent the problem.	Unit 5

Formula 24 Series Overview Chart

		Greenpower Focus	
The Number System	Compute fluently with multi-digit numbers and find common factors and multiples.		
	6NS.1	Fluently divide multi-digit numbers using the standard algorithm.	Unit 9
	6NS.2	Fluently add, subtract, multiply, and divide multi-digit decimals using the standard algorithm for each operation.	Unit 9
	Apply and extend previous understandings of numbers to the system of rational numbers.		
	6NS.6	Understand a rational number as a point on the number line. Extend number line diagrams and coordinate axes familiar from previous grades to represent points on the line and in the plane with negative number coordinates.	Unit 9
	6NS.7	Understand ordering and absolute value of rational numbers.	Unit 9
	6NS.8	Solve real-world and mathematical problems by graphing points in all four quadrants of the coordinate plane. Include use of coordinates and absolute value to find distances between points with the same first coordinate or the same second coordinate.	Unit 9
	Expressions and Equations	Apply and extend previous understandings of arithmetic to algebraic expressions.	
6EE.9		Use variables to represent two quantities in a real-world problem that change in relationship to one another; write an equation to express one quantity, thought of as the dependent variable, in terms of the other quantity, thought of as the independent variable. Analyze the relationship between the dependent and independent variables using graphs and tables, and relate these to the equation.	Units 4 and 5
Solve real-world and mathematical problems using numerical and algebraic expressions and equations.			
7EE.3		Solve multistep real-life and mathematical problems posed with positive and negative rational numbers in any form (whole number, fractions, and decimals), using tools strategically. Apply properties of operations to calculate with numbers in any form, convert between forms as appropriate, and assess the reasonableness of answers using mental computation and estimation strategies.	Unit 3

Formula 24 Series Overview Chart

Formula 24 Series Overview Chart			Greenpower Focus
Expressions and Equations	7EE.4	Use variables to represent quantities in a real-world or mathematical problem, and construct simple equations and inequalities to solve problems by reasoning about the quantities.	Units 4 and 5
	Understand the connections among proportional relationships, lines, and linear equations.		
	8EE.5	Graph proportional relationships, interpreting the unit rate as the slope of the graph. Compare two different proportional relationships represented in different ways.	Units 5 and 9
	A-CED1	Create equations and inequalities in one variable, and use them to solve problems. Include equations arising from linear and quadratic functions, and simple rational and exponential functions.	Units 4 and 5
	A-CED2	Create equations in two or more variables to represent relationships between quantities; graph equations on coordinate axes with labels and scales.	Units 4 and 5
	A-CED4	Rearrange formulas to highlight a quantity of interest, using the same reasoning as in solving equations.	Unit 9
Functions	Interpreting Functions		
	F-IF4	For a function that models a relationship between two quantities, interpret key features of graphs and tables in terms of the quantities, and sketch graphs showing key features given a verbal description of the relationship.	Units 4 and 9
Algebraic Connections (Alabama)	Graphing		
	AC-5	Determine approximate rates of change of nonlinear relationships from graphical and numerical data. (Alabama)	Units 4 and 9
	Finance		
	AC-7	Use analytical, numerical, and graphical methods to make financial and economic decisions, including those involving banking and investments, insurance, personal budgets, credit purchases, recreation, and deceptive and fraudulent pricing and advertising. (Alabama)	Unit 2
	Geometry		
AC-8	Determine missing information in an application-based situation using properties of right triangles, including trigonometric ratios and the Pythagorean Theorem. (Alabama)	Unit 8	

Formula 24 Series Overview Chart			Greenpower Focus
Statistics and Probability	Summarize and describe distributions.		
	6SP.4	Display numerical data in plots on a number line, including dot plots, histograms, and box plots.	Units 5 and 9
	6SP.5	Summarize numerical data sets in relation to their context.	Units 5 and 9
	S-ID6	Represent data on two quantitative variables on a scatter plot, and describe how the variables are related.	Unit 9
	A-12	Create a model of a set of data by estimating the equation of a curve of best fit from tables of values or scatter plots. (Alabama)	Unit 9
	Draw informal comparative inferences about two populations.		
	7SP.3	Informally assess the degree of visual overlap of two numerical data distributions with similar variabilities, measuring the difference between the centers by expressing it as a multiple of a measure of variability.	Unit 9
	7SP.4	Use measures of center and measures of variability for numerical data from random samples to draw informal comparative inferences about two populations.	Unit 9
	Investigate patterns of association in bivariate data.		
	8SP.1	Construct and interpret scatter plots for bivariate measurement data to investigate patterns of association between two quantities. Describe patterns such as clustering, outliers, positive or negative association, linear association, and nonlinear association.	Units 5, 6, 9
	8SP.3	Use the equation of linear model to solve problems in context of bivariate measurement data, interpreting the slope and intercept.	Unit 4
	Ratios and Proportional Relationships	Analyze proportional relationships and use them to solve real-world and mathematical problems.	
7RP.1		Compute unit rates associated with ratios of fractions, including ratios of lengths, areas, and other quantities measured in like or different units.	Units 5 and 9
7RP.2		Recognize and represent proportional relationships between quantities.	Unit 5
7RP.3		Use proportional relationships to solve multistep ratio and percent problems.	Unit 5
The Number System	Apply and extend previous understandings of operations with fractions to add, subtract, multiply, and divide rational numbers.		
	7NS.2	Apply and extend previous understandings of multiplication and division and of fractions to multiply and divide rational numbers.	Unit 5
	7NS.3	Solve real-world and mathematical problems involving the four operations with rational numbers. (Computations with rational numbers extend the rules for manipulating fractions to complex fractions.)	Units 5 and 9

Formula 24 Series Overview Chart		Greenpower Focus	
Geometry	Draw, construct, and describe geometrical figures and describe the relationship between them.		
	7G.1	Solve problems involving scale drawings of geometric figures, including computing actual lengths and areas from a scale drawing and reproducing a scale drawing at a different scale.	Unit 3
	7G.2	Draw geometric shapes with given conditions. Focus on constructing triangles from three measures of angles or sides, noticing when the conditions determine a unique triangle, more than one triangle, or no triangle.	Unit 4
	7G.3	Describe the two-dimensional figures that result from slicing three-dimensional figures, as in plan sections of right rectangular prisms and right rectangular pyramids.	Unit 3
	Solve real-world and mathematical problems involving angle measure, area, surface area, and volume.		
	6G.1	Find the area of right triangles, other triangles, special quadrilaterals, and polygons by composing into rectangles or decomposing into triangles and other shapes; apply these techniques in the context of solving real-world and mathematical problems.	Unit 8
	6G.4	Represent three-dimensional figures using nets made up of rectangles and triangles, and use the nets to find the surface area of these figures. Apply these techniques in the context of solving real-world and mathematical problems.	Unit 8
	7G.4	Know the formulas for the area and circumference of a circle, and use them to solve problems; give an informal derivation of the relationship between the circumference and area of a circle.	Units 4 and 5
	7G.5	Use facts about supplementary, complementary, vertical, and adjacent angles in a multistep problem to write and solve simple equations for an unknown angle in a figure.	Unit 4
	7G.6	Solve real-world and mathematical problems involving area, volume, and surface area of two- and three-dimensional objects composed of triangle, quadrilaterals, polygons, cubes, and right prisms.	Units 3, 4, 8
	Understand congruence and similarity using physical models, transparencies, or geometry software.		
	8G.5	Use informal arguments to establish facts about the angle sum and exterior angle of triangles, about the angles created when parallel lines are cut by a transversal, and the angle-angle criterion for similarity of triangles.	Unit 4

Formula 24 Series Overview Chart

Greenpower Focus

Geometry	G-CO2	Represent transformations in the plane using, e.g., transparencies and geometry software; describe transformations as functions that take points in the plane as inputs and give other points as outputs. Compare transformations that preserve distance and angle to those that do not (e.g., translation versus horizontal stretch).		
	G-CO4	Develop definitions of rotations, reflections, and translations in terms of angles, circles, perpendicular lines, parallel lines, and line segments.		
	G-CO5	Given a geometric figure and a rotation, reflection, or translation, draw the transformed figure using, e.g., graph paper, tracing paper, or geometry software. Specify a sequence of transformations that will carry a given figure onto another.		
	G-CO12	Make formal geometric constructions with a variety of tools and methods such as compass and straightedge, string, reflective devices, paper folding, and dynamic geometric software. <i>Constructions include copying a segment; copying an angle; bisecting a segment; bisecting an angle; constructing perpendicular lines, including the perpendicular bisector of a line segment; and constructing a line parallel to a given line through a point not on the line</i>	Units 3 and 8	
	Understand and apply the Pythagorean Theorem.			
	8G.7	Apply the Pythagorean Theorem to determine unknown side lengths in right triangles in real-world and mathematical problems in two and three dimensions.	Unit 7	
	G-SRT8	Use trigonometric ratios and the Pythagorean Theorem to solve right triangles in applied problems.	Unit 7	
	Modeling			
	G-MG1	Use geometric shapes, their measures, and their properties to describe objects (e.g., modeling a tree trunk or a human torso as a cylinder).	Unit 8	
	G-MG3	Apply geometric methods to solve design problems (e.g., designing an object or structure to satisfy physical constraints or minimize cost, working with typographic grid systems based on ratios) G-MG3	Unit 8	

AC – Algebraic Connections (Alabama)

Formula 24 Series Overview Chart		Greenpower Focus	
Science	Health		
	Life Science		
	LS7.4	Construct models and representations of organ systems (e.g., circulatory, digestive, respiratory, muscular, skeletal, nervous) to demonstrate how multiple interacting organs and systems work together to accomplish specific functions.	Unit 7
	Physical Science		
	PS8.1	Identify steps within the scientific process.	Units 5 and 8
	PS8.8	Identify Newton's three laws of motion.	Units 3, 4, 7, 8
	PS8.9	Describe how mechanical advantages of simple machines reduce the amount of force needed for work.	Units 3, 4, 5, 7
	PS8.10	Differentiate between potential and kinetic energy.	Unit 4,7
	PS8.11	Explain the law of conservation of energy and its relationship to energy transformation, including chemical to electrical, chemical to heat, electrical to light, electrical to mechanical, and electrical to sound.	Units 4, 5, 6, 7
	PS9-12.10	Construct simple series and parallel circuits containing resistors and batteries and apply Ohm's law to solve typical problems demonstrating the effect of changing values of resistors and voltages.	Unit 6
	PS9-12.12	Design, build, and test the ability of a device (e.g., Rube Goldberg devices, wind turbines, solar cells, solar ovens) to convert one form of energy into another form of energy.	Unit 5
	Human Anatomy and Physiology		
	HAP9-12.4	Use models to identify the structure and function of the skeletal system (e.g., classification of bones by shape, classification of joints and the appendicular and axial skeletons). b. Obtain and communicate information to demonstrate understanding of the pathology of the skeletal system (e.g., types of bone fractures and their treatment, osteoporosis, rickets, other bone diseases).	Unit 7
	HAP9-12.6	Obtain, evaluate, and communicate information regarding how the central nervous system and peripheral nervous system interrelate, including how these systems affect all other body systems to maintain homeostasis. a. Use scientific evidence to evaluate the effects of pathology on the nervous system (e.g., Parkinson's disease, Alzheimer's disease, cerebral palsy, head trauma) and argue possible prevention and treatment options.	Unit 7

Formula 24 Series Overview Chart

		Greenpower Focus
Science	Environmental	
	ES9-12.1	Investigate and analyze the use of nonrenewable energy sources (e.g., fossil fuels, nuclear, natural gas) and renewable energy sources (e.g., solar, wind, hydroelectric, geothermal) and propose solutions for their impact on the environment.
	ES9-12.14	Analyze cost-benefit ratios of competing solutions for developing, conserving, managing, recycling, and reusing energy and mineral resources to minimize impacts in natural systems (e.g., determining best practices for agricultural soil use, mining for coal, and exploring for petroleum and natural gas sources)
		Unit 1
		Unit 1

Formula 24 Series Overview Chart		Greenpower Focus	
Technology Education*	6 th – 8th		
	TE6-8.5	Use basic features of word processing, spreadsheets, databases, and presentation software.	Units 2, 3, 5, 6, 7
	TE6-8.6	Select specific digital tools for completing curriculum-related tasks.	Units 2
	TE6-8.8	Identify safe uses of social networking and electronic communication.	Unit 2
	TE6-8.9	Practice responsible and legal use of technology systems and digital content.	Unit 2 and 5
	TE6-8.11 TE9-12.12	Use digital tools and strategies to locate, collect, organize, evaluate, and synthesize information.	Units 2, 3, 5, 6, 7, 9
	9 th – 12th		
	TE9-12.5	Utilize advanced features of spreadsheet software, including creating charts and graphs, sorting and filtering data, creating formulas, and applying functions.	Units 2,5,6,9
	TE9-12.6	Utilize advanced features of multimedia software, including image, video, and audio editing.	Units 2,5
	TE9-12.8	Practice safe uses of social networking and electronic communication.	Unit 2
	TE9-12.9	Practice ethical and legal use of technology systems and digital content.	Units 2,3,5,8
	TE9-12.11	Critique digital content for validity, accuracy, bias, currency, and relevance.	Units 2,3,5,8
	TE9-12.14	Use digital tools to defend solutions to authentic problems.	Unit 3
	TE9-12.16	Create a product that integrates information from multiple software applications.	Units 2,3,6

* AL Technology Education Standards

Formula 24 Series Overview Chart		Greenpower Focus	
Career and Technical Education Standards*	Sales and Promotion		
	CTE S&P 9-12.4	Design an advertising and promotional campaign, including identifying a target market, determining media use, preparing a budget, and developing a timeline for a product or service.	Unit 2
	STEM Foundations of Engineering		
CTE FE 9-12.1	Demonstrate skills for employment in the engineering field, including preparing job résumés and applications.	Unit 2	

*AL Career and Technical Education Standards (9-12)

Formula 24 Series Overview Chart		Greenpower Focus	
College and Career Readiness Literacy Anchor Standards for Technology Subjects* Writing (6-12)	Text Types and Purposes		
	CCRASL*- W1	Write arguments to support claims with clear reasons and relevant evidence.	Units 1, 2, 3, 5,6,7,8,9
	CCRASL*- W2	Write informative or explanatory texts to examine a topic and convey ideas, concepts, and information through the selection, organization, and analysis of relevant content.	Units 2,3,4, 5,6,7,8,9
	Production and Distribution		
	CCRASL*- W4	Produce clear and coherent writing in which the development, organization, and style are appropriate to task, purpose, and audience.	Units 1, 2, 3, 4,6,7,8,9
	CCRASL*- W5	With some guidance and support from peers and adults, develop and strengthen writing as needed by planning, revising, editing, rewriting, or trying a new approach, focusing on how well the purpose and audience have been addressed.	Units 1, 2, 3, 4,6,7,8,9
	CCRASL*- W6	Use technology, including the Internet, to produce and publish writing and present the relationships between information and ideas efficiently as well as to interact and collaborate with others.	Units 2, 3 and 5
	Research to Build and Present Knowledge		
	CCRASL*- W7	Conduct short research projects to answer a question (including a self-generated question), drawing on several sources and generating additional related, focused questions that allow for multiple avenues of exploration.	Unit 3
	CCRASL*- W8	Gather relevant information from multiple print and digital sources, using search terms effectively; assess the credibility and accuracy of each source; and quote or paraphrase the data and conclusions of others while avoiding plagiarism and following a standard format for citation.	Units 1,2,3, 4,5,7
	CCRASL*- W1-9	Draw evidence from literary or informational texts to support analysis, reflection, and research.	Units 1,2,3,4, 5,6,7 8,9
	Range of Writing		
	CCRASL*- W10	Write routinely over extended time frames, including time for research, reflection, and revision, and shorter time frames such as a single sitting or a day or two for a range of discipline-specific tasks, purposes, and audiences.	Units 1,2,3,4, 6,7,8,9

Formula 24 Series Overview Chart			Greenpower Focus
College and Career Readiness Literacy Anchor Standards for Technology Subjects* Reading (6-12)	Craft & Structure		
	CCRASL-R1	Cite specific textual evidence to support analysis of science and technical texts.	Units 2 and 8
	CCRASL-R3	Follow precisely a multistep procedure when carrying out experiments, taking measurements, or performing technical tasks.	Units 4 and 9
	CCRASL-R4	Determine the meaning of symbols, key terms, and other domain-specific words and phrases as they are used in a specific scientific or technical context relevant to 9-10 texts and topics.	Units 4 and 5
	CCRASL-R5	Analyze the structure of the relationships among concepts in a text, including the relationships among key terms (e.g. force, friction, reaction forces, energy.)	Units 3,4,5,7,8
	Integration of Knowledge & Ideas		
	CCRASL-R7	Translate quantitative or technical information expressed in words in a text into visual form (e.g., a table or chart) and translate information expressed visually or mathematically (e.g., in an equation) into words.	Units 2 and 5
	CCRASL-R8	Assess the extent to which the reasoning and evidence in a text support the author's claim or a recommendation for solving a scientific or technical problem	Units 3 and 8
	CCRASL-R9	Compare and contrast findings presented in a text to those from other sources (including their own experiments), noting when the findings support or contradict previous explanations or accounts.	Unit 3